

Centrale elettronica
Electronic control unit
Centrale électronique
Elektronische Steuereinheit
Central electrónica
Central electrónica
Elektroniczna jednostka sterująca
Electrische zekering

900CT-201

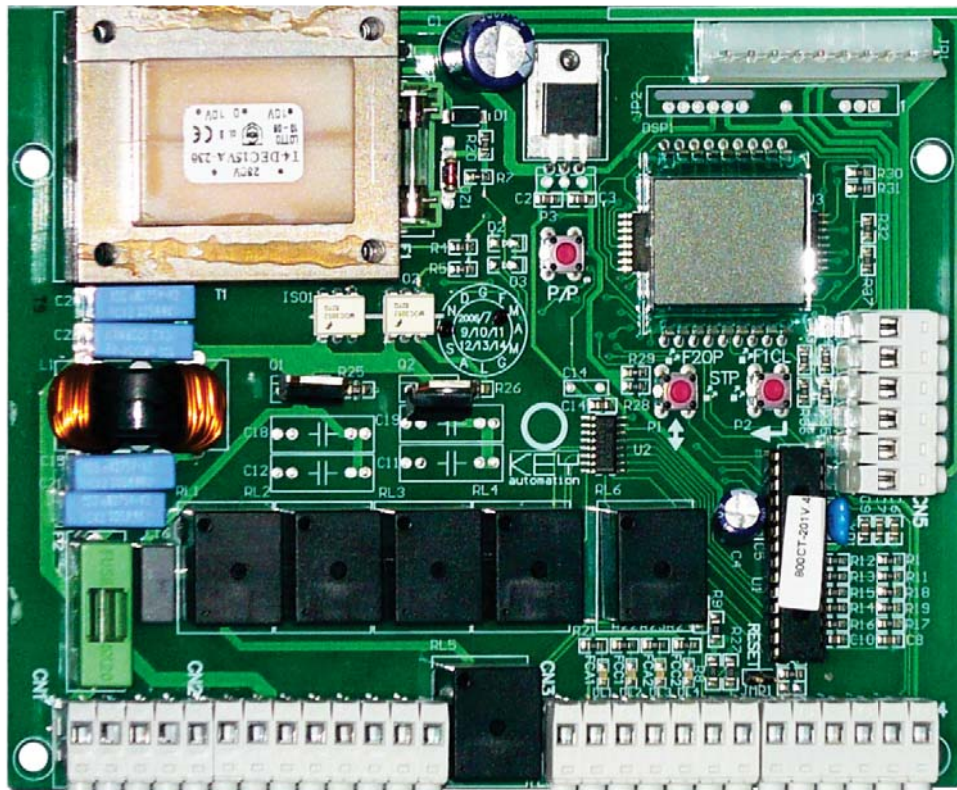

- Ⓜ IT MANUALE ISTRUZIONI
- Ⓜ GB INSTRUCTION MANUAL
- Ⓜ F MANUEL D'EMPLOI
- Ⓜ D BEDIENUNGSANLEITUNG
- Ⓜ E MANUAL DE INSTRUCCIONES
- Ⓜ P MANUAL DE INSTRUÇÕES
- Ⓜ PL INSTRUKCJA OBSŁUGI
- Ⓜ NL GEBRUIKSHANDLEIDING



Key Automation S.p.A



Organizzazione con Sistema di Gestione certificato
Company with Management System certified

ISO 9001:2008

SINCERT

⚠ WARNING: 

It is advisable to read the instructions carefully before you start installation.

Failure to comply with these instructions, improper use or incorrect connection may compromise the safety or correct operation of the device and hence of the entire system.

No liability shall be accepted for any malfunctions and/or damage due to failure to comply with the instructions.

The company reserves the right to make improvements to the products.

⚠ THIS BOOKLET IS TO BE USED ONLY BY THE INSTALLER

Installation must be carried out only by professionally qualified personnel in compliance with current legal requirements.

 ELECTRICAL CONNECTIONS

To ensure operator safety and to prevent damage to the components while connections are being made, or when the radio card is being inserted, the control unit absolutely must not be powered on. For power cords, motor lines, flasher/courtesy light line, and electric lock, use a cable with a cross-section that is suitable for the length (minimum 1.5 mm²).

For auxiliary power supplies, controls and safety contacts a minimum section of 0,5 mm². When the control cables are very long (more than 30 m), de-coupling is suggested using relays at the control unit.

If a fuse trips, after removing the cause, replace it with another one of the same type. Install the various safety devices, limit switches, photocells, sensitive rib, stop button.

If one or more of the safety devices are not installed, the corresponding terminals must be short circuited with the controls common.

All contacts N.C. Assigned to the same input must be connected in series.

All contacts N.O. Assigned to the same input must be connected in parallel.

Provide disconnecting devices in the power supply network in accessible places.

For the power supply of the control unit, there must be an external disconnecting switch (not included), independent and properly sized.

⚠ ATTENZIONE 

I dati e le informazioni indicate in questo manuale sono da ritenersi suscettibili di modifica in qualsiasi momento e senza obbligo di preavviso da parte di Key Automation S.p.A.

MODELS AND CHARACTERISTICS

900CT-201 Control unit for 1/2 motors, 230Vdc, set up for radio card, plastic box included
 The control unit is designed to automate opening of 1/2 motors for hinged automation with maximum power of 700W ea. with active and passive safety controls for installation that is compliant with current safety standards.

TECHNICAL DATA	CT-201
POWER SUPPLY	230Vac/50Hz
MAX. MOTOR LOAD	700W+700W
ACCESSORIES POWER SUPPLY OUTPUT	24Vac 400mA
WORKING TIME	0-120sec
PAUSE TIME	0-120sec
OPERATING TEMPERATURE	-20°C/+70°C
DEGREE OF PROTECTION	IP54

OVERALL VIEW

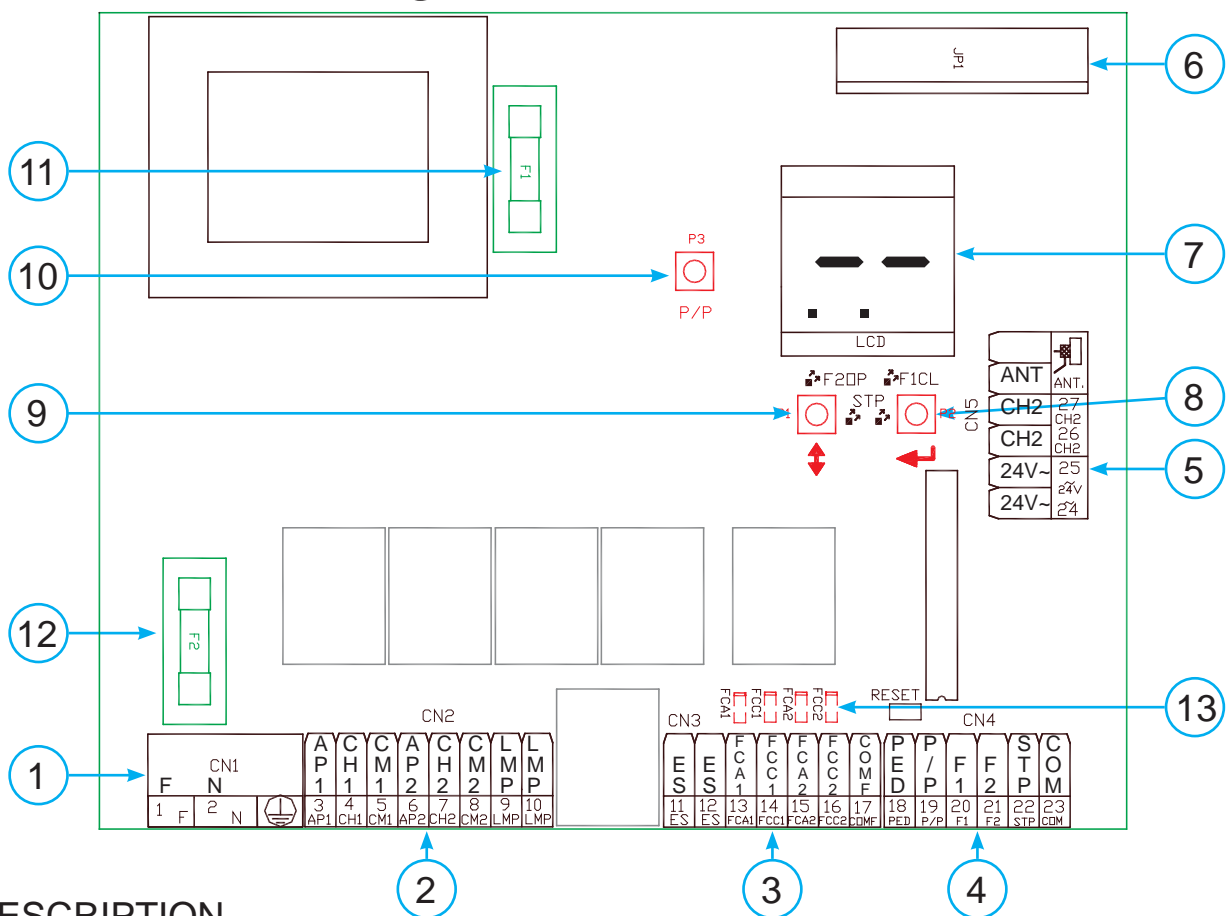

DESCRIPTION

- ① CN1 Connections of power supply and earth
- ② CN2 Connection of motors / flasher
- ③ CN3 Connection of electric lock, limit switch
- ④ CN4 Connection of controls and safeties
- ⑤ CN5 Connection of 24Vac, accessories power supply and second radio channel
- ⑥ JP1 Connector for snap-in radio receiving card
- ⑦ LCD Display for signalling functions and safety inputs
- ⑧ ENTER button for scrolling programming functions
- ⑨ UP/DOWN button for function settings (see table)
- ⑩ P/P Step/step button
- ⑪ F1 Fuse accessory line protection 230Vac 1.6A delayed
- ⑫ F2 Fuse line protection 230Vac 5A delayed
- ⑬ FCA1 FCC1 FCA2 FCC2 signal led of limit switch

CN1

power supply of the board:

- 1) F Phase 230Vac
- 2) N Neutral 230Vac
- ≐) T Ground

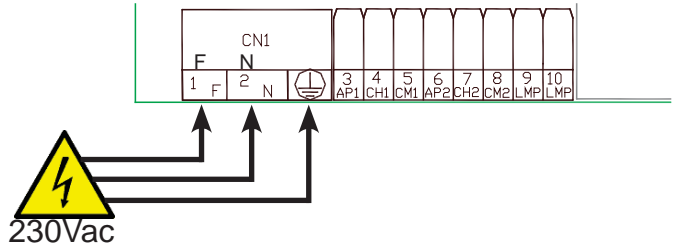

CN2

- 3) opening M1
- 4) closing M1
- 5) common M1
- 6) opening M2
- 7) closing M2
- 8) common M2
- 9) flasher Max 25W 230Vac
- 10) flasher Max 25W 230Vac

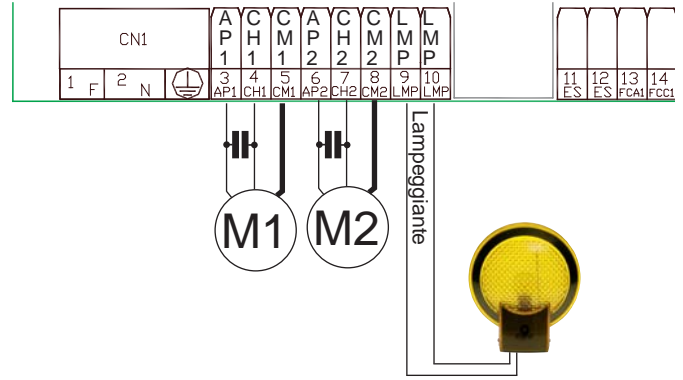

CN3

- 11) ELS electric lock or open gate light
- 12) ELS electric lock or open gate light
- 13) FCA1 limit switch opening M1
- 14) FCC1 limit switch closing M1
- 15) FCA2 limit switch opening M2
- 16) FCC2 limit switch closing M2
- 17) COMF limit switch common

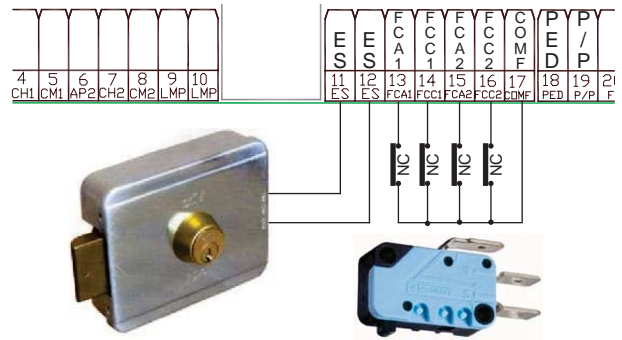

N.B. The LED's that correspond to the limit switches are ON when the relative limit switch is not involved, if you do not use the limit switch they must be jumper connected to the COMF terminal

CN4

- 18) PED pedal function
*Connected between Term. N.18 and Term. N.23 Contact N.O. Normally open
This is an opening control with, if 2-motor operation is selected, will completely open only motor M1.*
- 19) P/P Step/step operation
*Connected between Term. N.19 and Term. N.23 Contact N.O. Normally open
Control input open/close or open/stop/close based on selection of parameter D*
- 20) Photocell Close Function F1 :
*Connected between Term. N.20 and Term. N.23 Contact N.C. Normally Closed
This input is considered a safety, the contact can be interrupted at any time during closing of the automation causing an immediate stop in movement and reversing the direction of movement*
- 21) Photocell Open Function F2 :
*Connected between Term. N.21 and Term. 23 Contact N.C. Normally closed
This input is considered a safety, the contact can be interrupted at any time during opening by the automation causing an immediate stop in movement, the automation will continue until the contact is restored.*

- 22) Stop function STP :
 Connected to Term. N.22 and Term. N.23 Contact Normally Open N.C. This input is considered a safety the contact can be interrupted at any time immediately stopping the automation disabling any function including automatic closing.
- 23) COM common

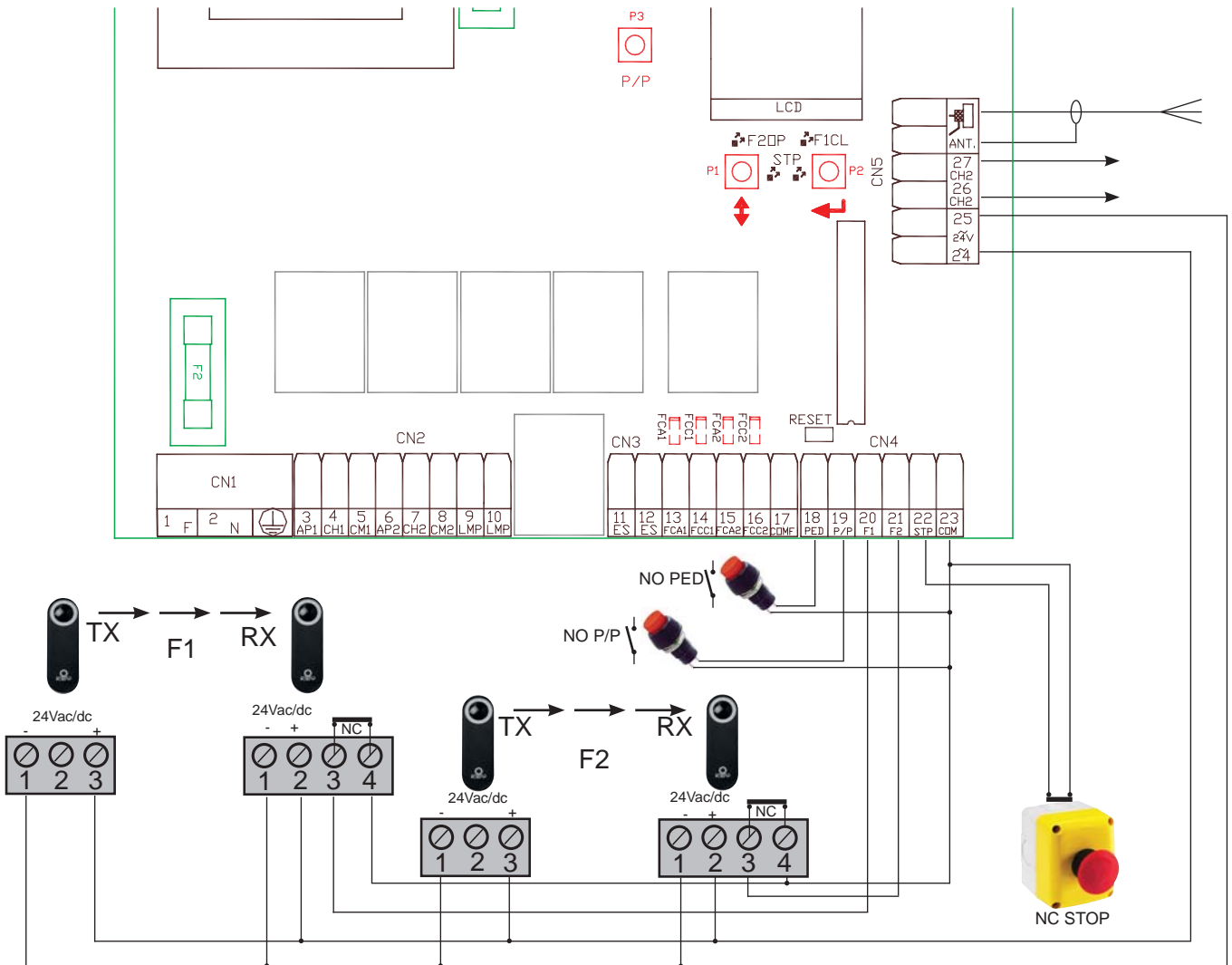

CN5

- 24) Accessory power supply connection 24Vac 15W max
 25) Accessory power supply connection 24Vac 15W max
 26) 2nd radio channel connection (only if using 2-channel radio connector)
 27) 2nd radio channel connection (only if using 2-channel radio connector)
 28) Antenna connection (mesh)
 29) Antenna connection (signal)

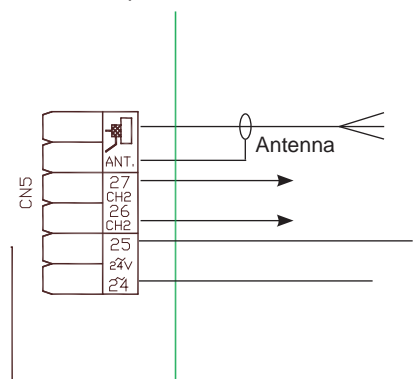

VISUAL DIAGNOSIS

The great reliability of the system and the high concentration of the functions are managed by a micro-controller so that the system can calculate all deceleration parameters based on the set working times with no special programming by the installer.

The unit is equipped with basic programming that will provide you with the fundamental selected parameters. Only the following procedure is required for first start-up:

- Check whether the system has 1 motor or 2 motors and select the type via parameter M

- Check the optimal working time to be selected via parameter A based on the maximum opening and based on the type used where Key Automation provides you with the table of times to be selected for 90° as follows:

MOTOR	TIME
PS-300	13 sec.
PS-400	18 sec.
INT / INTOIL	23 sec.
SN-50 / SN-50B	16 sec.

- After checking that the working time is sufficient to ensure complete opening and closing, the programming functions can be adjusted: motor force, deceleration, etc.



- The input STOP no. 22, which requires use of an NC contact, must be closed and the two points of the LCD must not flash. If they flash, it means the contact is open.

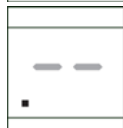

- The input PHOTO OPEN no. 21, which requires use of an NC contact, must be closed and the point of the LCD on the left must be off. If it is on steady it means that the contact is open.

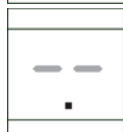

- The input PHOTO CLOSE no. 20, which requires use of an NC contact, must be closed and the point of the LCD on the left F1CL must be off. If it is on steady it means that the contact is open

N.B. In normal use, the points of the LCD must not flash or be on steady. They flash or stay on if the corresponding safety is activated.

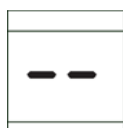

- With the automation closed, -- will be shown



- During opening the display will show OP.



- If you have selected automatic operation, TC will be shown in the pause time



- During closing the display will show CL.



- If ST (stop) is shown, it means that the DEAD MAN function is enabled and the complete opening or closing cycle has not ended.



- After checking that the working time is sufficient to ensure complete opening and closing, the programming functions can be adjusted: motor force, deceleration, etc.

PROGRAMMING FUNCTIONS

Access the parameter menu by holding the ENTER button until the first parameter, A, appears. Press the ENTER button repeatedly to advance through the parameters menu. To change the parameter press ↑ UP/DOWN

N.B.: any variation in function must be made with the automation closed

FUNCTIONS \ VALUES		0	1	2	3	4	5	6	7	8	9	10
A	WORKING TIME M1 (seconds)	5	6	9	12	15	18	21	24	27	30	+3sec
.A	WORKING TIME M2 (seconds)	5	6	9	12	15	18	21	24	27	30	+3sec
B	M1 DELAY TIME (seconds)	--	0	1	4	10	With this selection you can delay start-up of the second motor M1 by the set time					
C	AUTOMATIC CLOSURE (seconds)	NO	5	10	15	20	25	30	40	80	120	
D	OPEN COMMAND	Open Stop close	Open Close	By activating the step/step function, you avoid passage of the automation in the stop state. The enabled function may be critical for automations with high inertia.								
E	% DECELERATION	NO	10%	20%	30%	When the deceleration function is activated in the last seconds of operation of the automation, the control unit slows the motors based on the selected %.						
F	ELECTRIC LOCK HAM-MERING	NO	YES	If you select the Hammering parameter, the control unit facilitates the release of the electric lock, ordering the motors to close for a short time								
G	FLASHER OUTPUT	Flashing	Courtesy light	With this selection you can select output N°9-10 as flasher or courtesy light								
H	CONDOMINIUM (OPENING ONLY)	NO	YES	Activate the condominium function so that the first step/step impulse opens and accepts only re-opening during closing								
I	MOTOR WARM-UP (minutes)	NO	15	25	40	If you insert parameter I = from 1 to 3 and if the gate is standing closed in standby at the end of the set time there will be a closure of both doors of 1 min. at a value of power that does not damage the motor or the mechanics. This makes it possible to keep the internal temperature of the electric motor at a point where ice does not form in the mechanical reduction gear. This function should be used when temperatures of less than 5°C are expected.						
L	MOTOR FORCE	100% Max	10% Min	20%	30%	40%	50%	60%	70%	80%	90%	
N	N° OF MOTORS	2	1	Parameter of selection of automation with 1 or 2 motors								
O	CLOSE AFTER TRANSIT	NO	YES	When you activate the Close After Transit function with automatic closure activated, the automation is closed in the shortest time possible without waiting for automatic re-closing.								
P	TIMER/MAGNETIC COIL ON STEP/STEP	NO	YES	When you activate the function Timer / Magnetic Coil via parameter P after terminating total opening if step/step contact is kept closed the automatic closing time is locked so that the gate never closes until the step/step contact is opened again, if there are several step/step impulses during the standby time for automatic closing the time will be continuously reset								
R	SOFT START	NO	YES	When you activate the Soft Start function, during the first seconds of movement of the automation the control unit keeps the motor at reduced speed for a softer start.								
T	ELECTRO LOCK / SCA (open gate light)	--	ELS	SCA	The SCA function (open gate light) allows the connection of a 12Vac signaling light, max 1W, in the electro lock output							
U	DEAD MAN FUNCTION	NO	YES	When you activate the dead man function via parameter U, you can open the automation until step/step contact is closed and close the automation until contact PED is closed; when the two contacts are released the automation goes to STOP position.								
Y	PRE-FLASHING	NO	1sec	2sec	4sec	When the pre-flashing function is activated, before any movement in closing the flasher is activated for the selected time						

ENGLISH

NB. Upon termination of displaying of parameters, you will access the total manoeuvres counter, which are shown in two different screens where the thousands are indicated by the point lighting up. If you want to rest this counter, press and hold button P1 and P2 until 0000 is shown

N.B. If the point of the LCD on the left lights up, it means that 10,000 manoeuvres have been exceeded, which must be added to the value shown.

To exit parameter display, press ENTER several times until automatic closure condition is shown (-- two dashes).

ADJUSTMENT OF MOTOR FORCE

After a breakaway of 1.5 seconds, the electronic force control activates which distributes the power supply, adjusting the value by means of parameter L.

N.B. for maximum thrust loads refer to current standards.

RADIO CONNECTOR

The CT-201 unit is compatible with the following Key Automation receivers of the MEMO snap-in series: 900RXI-22 / 900RXI-42 / 900RXI-42R

FINAL WARNINGS

- The installation of the automation must be performed properly by qualified personnel in possession of legal requirements and in compliance with machine directive 98/37/CE and standards EN13241-1, EN 12453 and EN 12445.
- Check the solidity of existing structures (columns, hinges, doors) in relation to the force generated by the motor.
- Check that there are suitably sturdy mechanical stops at the end of opening and closing travel of the doors.
- Analyze the risks of the automation and adopt necessary safety measures and warnings.
- Install controls (such as the key selector) so that the user is not in a hazardous position.
- Upon completion of installation, check the safety devices several times, as well as those for signalling and automation release.
- Provide the automation with the EC label or tag that contains the danger information and identification data.
- Give the final user the instructions for use, safety warnings and the EC declaration of conformity.
- Make sure the user understands proper automatic, manual and emergency operation of the automation.
- Inform the user in writing (for example in the instructions for use) of any unprotected residual risks and foreseeable improper use.
- Provide a maintenance schedule for the system (at least every 6 months for the safeties) with an appropriate register of work performed.
- Keep this instruction manual for future reference.
- Key Automation S.p.A. reserves the right to make, at any time, any modifications which may be required to improve appearance and/or operation.

DISPOSAL



This product is composed of various components which may in turn contain pollutants. Do not dispose of it in the environment! Find out about the method for recycling or disposing of the product in compliance with current local laws.

