

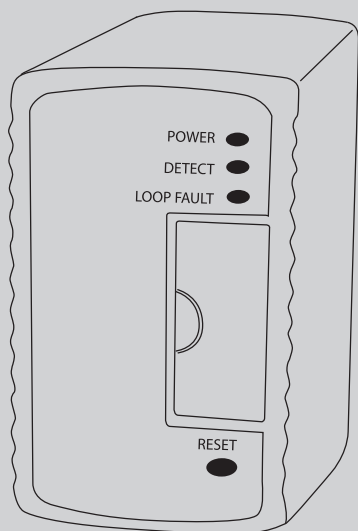

RILEVATORE DI VEICOLI A SPIRE  
 VEHICLE LOOP DETECTOR  
 DETECTEUR DE VÉHICULES A BOUCLE INDUCTIVE  
 INDUKTIONSSCHLEIFEN-DETEKTOR ZUR DETEKTION VON FAHRZEUGEN  
 DETECTOR DE VEHÍCULOS DE LAZO INDUCTIVO  
 LUSDETECTOR VOERTUIGEN  
 LAÇO DETECTOR DE VEÍCULOS  
 ΑΝΙΧΝΕΥΤΗΣ ΟΧΗΜΑΤΩΝ ΜΕ ΒΡΟΧΟΥΣ  
 INDUKCYJNY DETEKTOR POJAZDÓW  
 ПЕТЛЕВОЙ ДЕТЕКТОР ТРАНСПОРТНЫХ СРЕДСТВ  
 DETEKTOR VOZIDEL S INDUKČNÍ SMYČKOU  
 ARAÇLAR İÇİN DÖNGÜ DEDEKTÖRÜ



ISTRUZIONI DI INSTALLAZIONE  
 INSTALLATION MANUAL  
 INSTRUCTIONS D'INSTALLATION  
 MONTAGEANLEITUNG  
 INSTRUCCIONES DE INSTALACION  
 INSTALLATIEVOORSCHRIFTEN  
 INSTRUÇÕES DE INSTALAÇÃO  
 ΟΔΗΓΙΕΣ ΕΓΚΑΤΑΣΤΑΣΗΣ  
 INSTRUKCJE INSTALACJI  
 ИНСТРУКЦИИ ПО УСТАНОВКЕ  
 POKYNY PRO INSTALACI  
 MONTAJ BİLGİLERİ

# RAME1-RME1-BT

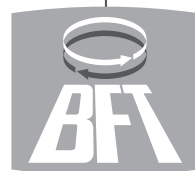

AZIENDA CON SISTEMA DI GESTIONE  
 INTEGRATO CERTIFICATO DA DNV  
 = UNI EN ISO 9001:2000 =  
 UNI EN ISO 14001:2004

RRME 1 and RME1 BT are two single-channel inductive loop detectors. By using microprocessor and surface-mount technology, a great many features can be integrated into a small space. RME 1 and RME1 BT are compatible with most commercially available single-channel detectors and are easy to set and install.

Typical applications in the parking and access control environments are safety loops, arming loops and entry or exit loops.

Standard features of the detector are :

- **Reset Switch.**

Pressing the reset switch enables the detector to be manually reset during commissioning and testing. This results in the detector re-tuning the sensing loop and becoming ready for vehicle detection.

- **Switch selectable Sensitivity.**

The detect sensitivity is the minimum change in inductance required to produce a detect output. (% $\Delta$ L/L)  
Eight sensitivity settings are available on the switches to allow flexibility in configuration.

1	High	-	0.01%	5	-	0.2%	
2		-	0.02%	6	-	0.5%	
3		-	0.05%	7	-	1%	
4		-	0.1%	8	Low	-	2%

- **Switch selectable Frequency.**

The frequency of the loop is determined by the inductance of the loop and the frequency switch setting. If the frequency switch is on, the frequency is reduced. It may be necessary to change the frequency to prevent cross-talk between adjacent loops.

- **Sensitivity Boost.**

This feature sets the undetect level to maximum sensitivity and is used to prevent loss of detection of high-bed vehicles.

- **Filter Option.**

This option is used to provide a delay of 2 Seconds between detection of the vehicle and switching of the output relay. This delay is normally used to prevent false detection of small or fast moving objects.

- **Permanent Presence Option.**

This feature ensures detection of the vehicle will be maintained when the vehicle is parked over the loop for extended periods.

- **Selectable Extend Time.**

When switched on this feature extends the outputs for 2 Seconds.

- **Pulse Relay Selection.**

The Pulse relay may be configured to energise on detection of a vehicle or when the vehicle leaves the loop.

- **Selectable Pulse Time.**

This feature sets the length of time that the pulse relay will be energised for. 1 Second or 0.2 Second.

- **Power Indicator.**

This LED Indicator illuminates when power is present.

- **Detect Indicator.**

This LED Indicator is illuminated when there is a vehicle over the loop or the loop is faulty. This LED can also be used to determine the loop frequency. On reset, count the number of times the LED flashes. Multiply this number by 10KHz. For example: if the LED flashes 6 times, then the loop frequency is between 60KHz and 70KHz.

- **Loop Fault Indicator.**

This LED Indicator is illuminated when the loop is either open circuit or short circuit and is used to give a visual indication of a faulty loop.

**DIAGNOSTICS:**

SYMPTOM	POSSIBLE CAUSE	SOLUTION
The POWER LED is not on.	No power supply voltage on the input.	Check that the power supply is correctly wired to the detector. (PINS 1 and 2)
The DETECT LED flashes erratically.	There may be a poor connection in the loop or loop feeder. The detector may be experiencing crosstalk with the loop of an adjacent detector.	Check all wiring. Tighten screw terminals. Check for broken wires. Try changing frequencies using the frequency switch. Put the detector with the larger loop onto low frequency and the detector with the smaller loop onto high frequency.
The DETECT LED randomly stays on.	Faulty loop or loop feeder wiring. Movement of the loop in the ground.	Check the wiring. Tighten screw terminals. Check for pinched or bent wires. Is the feeder wire twisted? Check for cracks in the road surface near the loop.
The LOOP FAULT LED is flashing.	The loop inductance is too small or the loop is short circuit.	Check that there is no short circuit on the loop feeder wiring or the loop. If there is no short circuit then the inductance is too small and more turns of wire should be added to the loop.
The LOOP FAULT LED is permanently illuminated.	The loop inductance is too large or the loop is open circuit.	Check that there is electrical continuity on the loop. This can be done using a multimeter on the ohms range ( $< 5 \Omega$ ). If the loop inductance is too large then try reducing the number of turns.

**WIRING DIAGRAM:**

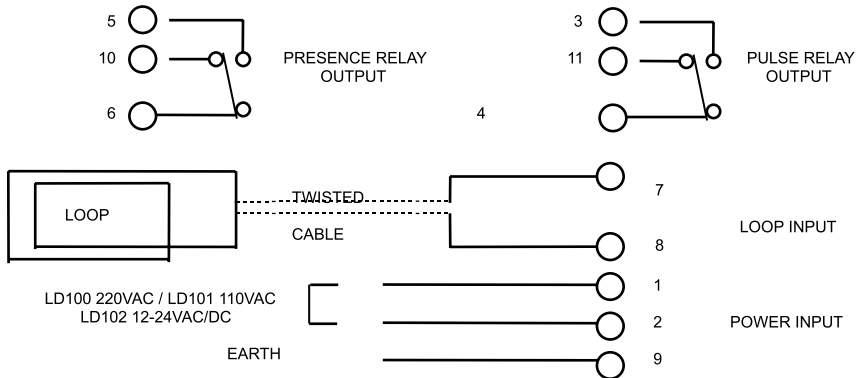

**TECHNICAL DATA**

<b>POWER REQUIREMENT:</b>	<b>RME 1</b> 200 - 260VAC 50Hz 1,5VA <b>RME 1 BT</b> 11 - 26VAC/DC 50/60Hz 95mA max.
<b>PRESENCE/PULSE RELAY :</b>	0.5A/220VAC.
<b>RESPONSE TIME:</b>	Approximately 120ms after vehicle enters loop.
<b>INDICATOR:</b>	LED indicators show: Power ,Detect state and Loop Fault.
<b>DETECTOR TUNING RANGE:</b>	15 - 1500 uH.
<b>PROTECTION:</b>	Loop isolation transformer with lightning protection.
<b>CONNECTOR:</b>	11 Pin Connector on rear of unit.
<b>DIMENSIONS:</b>	80mm (height) X 40mm (width) X 79mm (Depth excl. connector).
<b>SWITCH SETTINGS:</b>	

<b>SWITCH SETTINGS</b>			
<b>No.</b>	<b>FUNCTION</b>	<b>ON</b>	<b>OFF</b>
10	EXTEND TIME	2SECS	OFF
7,8,9	SENS 0.02%	-	S7/S8/S9
7,8,9	SENS 0.01%	S9	S7/S8
7,8,9	SENS 0.05%	S8	S7/S9
7,8,9	SENS 0.1%	S8/S9	S7
7,8,9	SENS 0.2%	S7	S8/S9
7,8,9	SENS 0.5%	S7/S9	S8
7,8,9	SENS 1%	S7/S8	S9
7,8,9	SENS 2%	S7/S8/S9	-
6	FREQUENCY	LOW	HI
5	ASB	ON	OFF
4	FILTER	2SEC	OFF
3	PERM. PRESENCE	ON	OFF
2	PULSE MODE	UNDET	DET
1	PULSE TIME	1 SEC	0.2SEC

**RELAY FUNCTIONALITY:**

RELAYS		VEHICLE PRESENT	NO VEHICLE	LOOP FAULTY	NO POWER
PRESENCE RELAY	N/O	CLOSED	OPEN	CLOSED	CLOSED
	N/C	OPEN	CLOSED	OPEN	OPEN
PULSE RELAY	N/O	PULSE CLOSED	OPEN	OPEN	OPEN
	N/C	PULSE OPEN	CLOSED	CLOSED	CLOSED

**INSTALLATION GUIDE:**

1. The detector should be installed in a waterproof housing as close to the loop as possible.
2. The loop and feeder should be made from insulated copper wire with a minimum cross-sectional area of 1.5mm<sup>2</sup>. The feeder should be twisted with at least 20 turns per metre. Joints in the wire are not recommended and must be soldered and made waterproof. Faulty joints could lead to incorrect operation of the detector. Feeders which may pick up electrical noise should use screened cable, with the screen earthed at the detector.
3. The loop should be either square or rectangular in shape with a minimum distance of 1 metre between opposite sides. Normally 3 turns of wire are used in the loop. Large loops with a circumference of greater than 10 metres should use 2 turns while small loops with a circumference of less than 6 metres should use 4 turns. When two loops are used in close proximity to each other it is recommended that 3 turns are used in one and 4 turns in the other to prevent cross-talk.
4. Cross-talk is a term used to describe the interference between two adjacent loops. To avoid incorrect operation of the detector, the loops should be at least 2 metres apart and on different frequency settings.
5. For loop installation, slots should be cut in the road using a masonry cutting tool. A 45° cut should be made across the corners to prevent damage to the wire on the corners. The slot should be about 4mm wide and 30mm deep. Remember to extend the slot from one of the corners to the road-side to accommodate the feeder.
6. Best results are obtained when a single length of wire is used with no joints. This may be achieved by running the wire from the detector to the loop, around the loop for 3 turns and then back to the detector. The feeder portion of the wire is then twisted. Remember that twisting the feeder will shorten its length, so ensure a long enough feeder wire is used.
7. After the loop and feeder wires have been placed in the slot, the slot is filled with an epoxy compound or bitumen filler.

