

- I** ATTUATORE PER CANCELLI SCORREVOLI A CREMAGLIERA
- GB** ACTUATOR FOR RACK SLIDING GATES
- F** ACTIONNEUR POUR PORTAILS COULISSANTS A CREMAILLERE
- D** SCHIEBETORANTRIEB
- E** SERVOMOTOR PARA CANCELAS CORREDERAS DE CREMALLERA
- P** ACCIONADOR PARA PORTÕES DE CORRER A CREMALLERA

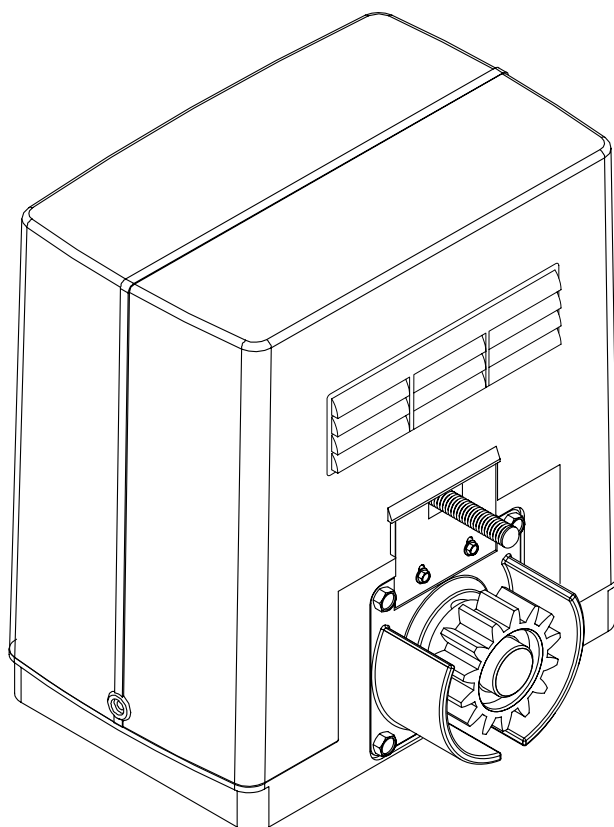

DEIMOS



ISTRUZIONI D'USO E DI INSTALLAZIONE
INSTALLATION AND USER'S MANUAL
INSTRUCTIONS D'UTILISATION ET D'INSTALLATION
INSTALLATIONS-UND GEBRAUCHSANLEITUNG
INSTRUCCIONES DE USO Y DE INSTALACION
INSTRUÇÕES DE USO E DE INSTALAÇÃO



AZIENDA CON SISTEMA QUALITÀ
CERTIFICATO DA DNV
=UNI EN ISO 9001/2000=

Via Lago di Vico, 44
 36015 Schio (VI)
 Tel.naz. 0445 696511
 Tel.int. +39 0445 696533
 Fax 0445 696522
 Internet: www.bft.it
 E-mail: sales@bft.it

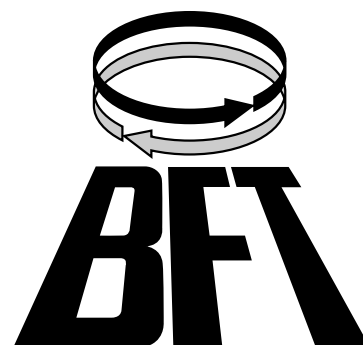

Thank you for buying this product, our company is sure that you will be more than satisfied with the product's performance. The product is supplied with a "Warnings" leaflet and an "Instruction booklet". These should both be read carefully as they provide important information about safety, installation, operation and maintenance. This product complies with the recognised technical standards and safety regulations. We declare that this product is in conformity with the following European Directives: 89/336/EEC and 73/23/EEC (and subsequent amendments).

1) GENERAL OUTLINE

The DEIMOS actuator offers ample installation versatility, thanks to the extremely low position of its pinion, its compact shape and the height and depth adjustments available. The adjustable mechanical clutch ensures antisquash safety and provides smooth progressive starting operations. The emergency manual release manoeuvre can be carried out very easily by means of a knob supplied with a standard key, or an optional personalised key. The end-of-stroke stop is controlled by electromechanical microswitches or, for very cold areas, by proximity sensors. The control unit can be either incorporated or fitted to a separate panel.

2) SAFETY

If correctly installed and used, this automation device satisfies the required safety level standards. However, it is advisable to observe some practical rules in order to avoid accidental problems.

Before using the automation device, carefully read the operation instructions and keep them for future reference.

- Keep children, persons and things outside the automation working area, particularly during operation.
- Keep radio control or other control devices out of children's reach, in order to avoid any unintentional automation activation.
- Do not intentionally oppose the leaf movement.
- Do not attempt to open the gate by hand, if the actuator has not been released by means of the appropriate release knob.
- Do not modify the automation components.
- In case of malfunction, disconnect the power supply, activate the emergency release to gain access to the actuator and request the assistance of a qualified technician (installer).
- Before proceeding to any external cleaning operation, disconnect the mains power supply and at least one of the battery pole, if fitted.
- Keep the photocell optical components and luminous signal indication devices clean. Check that the safety devices (photocells) are not obscured by branches or shrubs.
- For any direct assistance to the automation system, request the assistance of a qualified technician (installer).
- Have qualified personnel check the automation system once a year.

3) MANUAL RELEASE

The manual or emergency release is to be activated when a gate must be opened by hand, and in all cases where the automation system fails to operate or operates incorrectly. To carry out the emergency manoeuvre, proceed as follows:

- Insert the standard key into its appropriate seat (fig. 1) and rotate it anticlockwise (90°), then rotate the release knob clockwise along its entire stroke. This way the pinion is made to idle, and therefore allows the gate to be opened by hand.

Warning: Do not push the gate leaf hard, but rather help it along its entire stroke.

- To reset motor-driven control, rotate the knob anticlockwise along its entire stroke, and then rotate the standard key clockwise until it is held tight. Keep the key in a safe place which is known to all the people concerned.

In the case where the release knob is supplied with a personalised key (fig. 2), proceed as follows:

- Insert the personalised key into the lock, rotate the key anticlockwise by 90°.
- Hold the release knob and rotate it clockwise (fig. 2) until it stops. This way the pinion is made to idle, and therefore allows the gate to be opened by hand.
- Push the gate leaf by hand, helping it along its entire stroke. The key cannot be taken out of the lock until the knob is brought back to its initial position (motor-driven activation).
- To reset motor-driven control, rotate the knob anticlockwise along its entire stroke, move the key back to its locking position; then take the key out and keep it in a safe place which is known to all the people concerned.

4) MAINTENANCE AND DEMOLITION

The maintenance of the system should only be carried out by qualified personnel regularly. The materials making up the set and its packing must be disposed of according to the regulations in force.

WARNINGS

Correct controller operation is only ensured when the data contained in the present manual are observed. The company is not to be held responsible for any damage resulting from failure to observe the installation standards and the instructions contained in the present manual.

The descriptions and illustrations contained in the present manual are not binding. The Company reserves the right to make any alterations deemed appropriate for the technical, manufacturing and commercial improvement of the product, while leaving the essential product features unchanged, at any time and without undertaking to update the present publication.

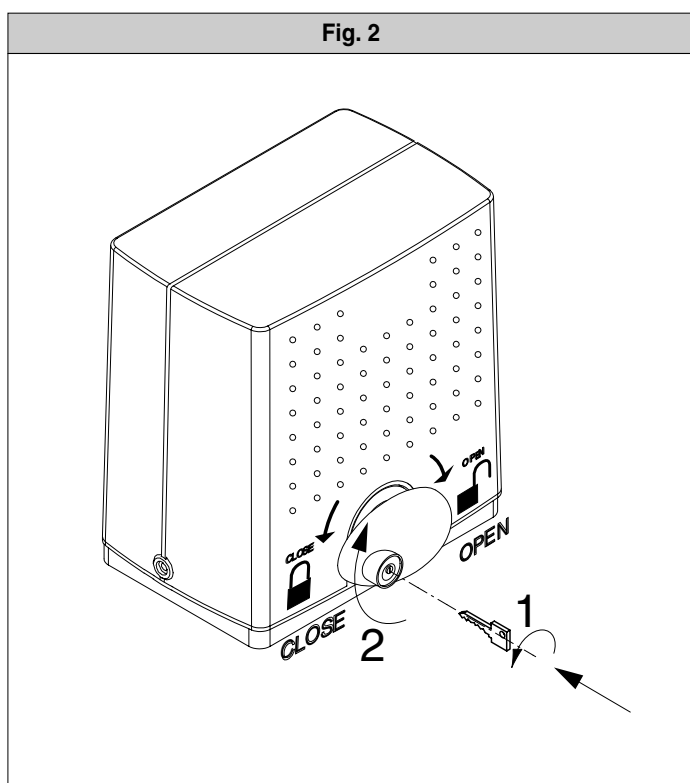
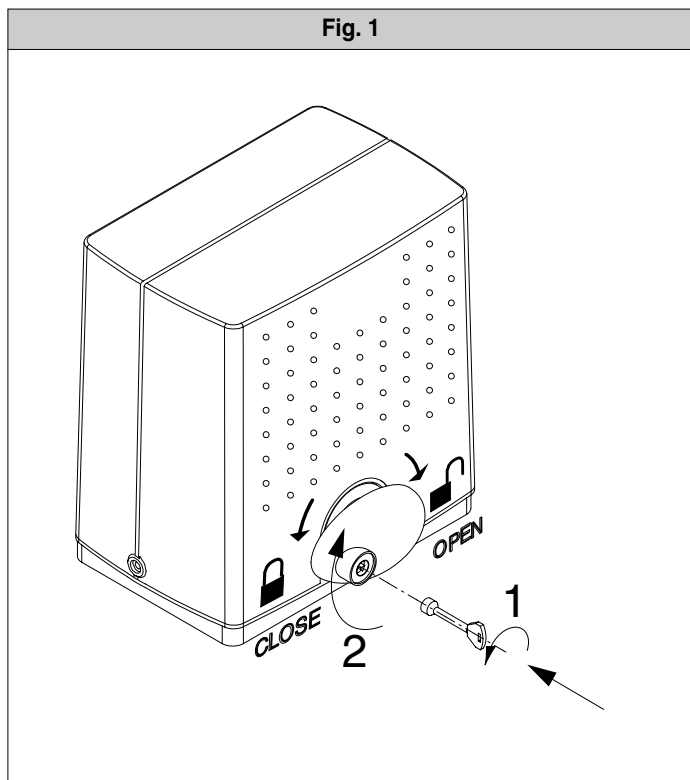

Thank you for buying this product, our company is sure that you will be more than satisfied with the product's performance. The product is supplied with a "Warnings" leaflet and an "Instruction booklet". These should both be read carefully as they provide important information about safety, installation, operation and maintenance. This product complies with the recognised technical standards and safety regulations. We declare that this product is in conformity with the following European Directives: 89/336/EEC and 73/23/EEC (and subsequent amendments).

1) GENERAL OUTLINE

The DEIMOS actuator offers ample installation versatility, thanks to the extremely low position of its pinion, its compact shape and the height and depth adjustments available. The adjustable mechanical clutch ensures antisquash safety and provides smooth progressive starting operations. The emergency manual release manoeuvre can be carried out very easily by means of a knob supplied with a standard key, or an optional personalised key. The end-of-stroke stop is controlled by electromechanical microswitches or, for very cold areas, by proximity sensors. The control unit can be either incorporated or fitted to a separate panel.

The gearmotor (fig. 1) comprises :

- "M" Motor
- "R" Reduction gear with worm screw – worm wheel
- "F" Mechanical clutch on motor shaft
- "S" Electromechanical limiting unit or proximity sensor
- "P" Pinion with release mechanism
- "C" Control unit and capacitor

2) GENERAL SAFETY

WARNING! An incorrect installation or improper use of the product can cause damage to persons, animals or things.

- The "Warnings" leaflet and "Instruction booklet" supplied with this product should be read carefully as they provide important information about safety, installation, use and maintenance.
- Scrap packing materials (plastic, cardboard, polystyrene etc) according to the provisions set out by current standards. Keep nylon or polystyrene bags out of children's reach.
- Keep the instructions together with the technical brochure for future reference.
- This product was exclusively designed and manufactured for the use specified in the present documentation. Any other use not specified in this documentation could damage the product and be dangerous.
- The Company declines all responsibility for any consequences resulting from improper use of the product, or use which is different from that expected and specified in the present documentation.
- Do not install the product in explosive atmosphere.
- The construction components of this product must comply with the following European Directives: 89/336/CEE, 73/23/EEC, 98/37/EEC and subsequent amendments. As for all non-EEC countries, the above-mentioned standards as well as the current national standards should be respected in order to achieve a good safety level.
- The Company declines all responsibility for any consequences resulting from failure to observe Good Technical Practice when constructing closing structures (door, gates etc.), as well as from any deformation which might occur during use.
- The installation must comply with the provisions set out by the following European Directives: 89/336/CEE, 73/23/EEC, 98/37/EEC and subsequent amendments.
- Disconnect the electrical power supply before carrying out any work on the installation.
- Fit an omnipolar or magnetothermal switch on the mains power supply, having a contact opening distance equal to or greater than 3mm.
- Check that a differential switch with a 0.03A threshold is fitted just before the power supply mains.
- Check that earthing is carried out correctly: connect all metal parts for closure (doors, gates etc.) and all system components provided with an earth terminal.
- Fit all the safety devices (photocells, electric edges etc.) which are needed to protect the area from any danger caused by squashing, conveying and shearing.
- Position at least one luminous signal indication device (blinker) where it can be easily seen, and fix a Warning sign to the structure.
- The Company declines all responsibility with respect to the automation safety and correct operation when other manufacturers' components are used.
- Only use original parts for any maintenance or repair operation.
- Do not modify the automation components, unless explicitly authorised by the company.

- Instruct the product user about the control systems provided and the manual opening operation in case of emergency.
- Do not allow persons or children to remain in the automation operation area.
- Keep radio control or other control devices out of children's reach, in order to avoid unintentional automation activation.
- The user must avoid any attempt to carry out work or repair on the automation system, and always request the assistance of qualified personnel.
- Anything which is not expressly provided for in the present instructions, is not allowed.

3) TECHNICAL DATA

Power supply:	single-phase 230V ~ ±10% 50Hz (*)
Motor revolutions:	1400 min ⁻¹
Absorbed power:	290W
Max absorbed power:	1,5A (230V ~) - 3A (110V ~)
Capacitor:	10 µF (230V ~) :40 µF (110V ~)
Thermal protection:	110°C
Insulation class:	F
Max leaf weight:	5000N (≈500kg)
Reduction ratio:	1/30
Output revolutions:	48 min ⁻¹
Pinion pitch:	4mm (14/18 teeth)
Leaf speed:	:8,5 m/min (14 teeth) :11m/min (18 teeth)
Impact reaction	: mechanical clutch
Lubrication:	Permanent grease
Manual manoeuvre:	Mechanical knob release
No. manoeuvres in 24 hours:	100
Control unit:	MIZAR-ELIX
Environmental conditions:	from -15°C to +60°C
Degree of protection:	IP24
Noise:	< 70dBA
Dimensions:	See fig.2
Controller weight:	15kg

(*) Special supply voltages on request.

4) PRELIMINARY CHECKS

Before proceeding to any installation work, check that the gate structure conforms to whatever is prescribed by the current standards, and in particular that:

- The gate sliding track is linear and horizontal, and the wheels are suitable for supporting the gate weight.
- The gate manual operation can be carried out smoothly along its entire run, and there is no excessive side slipping.
- A correct play is provided between the upper guide and the gate to ensure regular noiseless movement.
- The opening and closing gate stops are positioned.
- The established position for gearmotor fixing allows the emergency manoeuvre to be carried out smoothly and safely. In the case where the elements checked do not meet the above requirements, proceed to carrying out the necessary corrective actions or replacements.

WARNING: Remember that control devices are intended to facilitate gate operation, but can not solve problems due to any defects or deficiency resulting from failure to carry out correct installation or maintenance.

Take the product out of its packing and inspect it for damage. Should it be damaged, contact your dealer. Remember to dispose of its components (cardboard, polystyrene, nylon, etc.) according to the current prescriptions.

5) BASE PLATE ANCHORING

5.1) Standard position

- Dig a hole where the cement pad with the buried base plate log bolts is to be placed in order to fix the reduction gear unit (fig.3). If the sliding track is already there, digging must be partly carried out in the track foundation casting. This way, should the track foundation casting sag, the gearmotor base would also lower, thus maintaining the play between pinion and rack (approximately 1-2 mm).
- Position the base plate according to the dimensions specified in fig.4.
- The pinion symbol printed on the base plate must be visible and directed towards the gate. This also ensures the correct positioning of the raceways for electrical connections.
- Let the flexible pipes containing electrical cables protrude from the base plate.
- In order to keep the base plate in its correct position during installation, it may be useful to weld two iron flat bars under the track, and then weld

the log bolts onto them (fig.3).

- Make a concrete casting in such a way as to embody the base plate casting into that of the gate track.
- Accurately check that:
 - The positioning dimensions are correct.
 - That the base plate is well levelled.
 - That the 4 stud threads are well clear of cement.
 - Let the casting harden.

5.2) Other positions

The gearmotor can be positioned in different ways. As an example, fig.5 illustrates a particular type of installation. In the case where the gearmotor is not fixed on the level of the sliding track (**Standard position**), you must ensure that the gearmotor is tightly secured also in relation to the gate position, so as to maintain a correct play (1-2mm) between rack and pinion. The current safety standards with respect to persons, animals and things must be strictly observed, and in particular risks of accidents due to squashing in the area of pinion-rack meshing, as well as other mechanical risks, must be carefully avoided.

All the critical spots must be protected by safety devices in compliance with the current prescriptions.

6) GEARMOTOR FIXING

When the casting has hardened, observe fig. 6 and proceed as follows:

- Position an M10 nut on each of the tie rods, keeping a distance of at least 25mm from the base to allow the gearmotor to be lowered after the installation is completed, or for subsequent adjustments of the play between pinion and rack.
- Position a plate "P" supplied as standard on each pair of tie rods and, with the help of a level, adjust the plane in both directions.
- Remove the cover and screw-cover guard from the gearmotor, and position the reduction gear unit on the four tie rods with the pinion facing the gate.
- Position the four washers and screw the four gearmotor locking bolts.
- Adjust the depth of the gearmotor, making it slide in the appropriate slots found in the base, and fix it at a distance between pinion and gate which is adequate to the type of rack to be installed. The rack teeth must mesh into the pinion along their entire width. In the paragraph headed "**Rack fitting**" we specify the measurements and installation methods of the most widely used types of rack.

7) RACK FITTING

A rack having a 4 tooth pitch must be fitted to the gate. As far as the length is concerned, this must include the passage space, as well as the space for securing the brackets activating the limit microswitches, and for the pinion meshing section. There are different types of rack, each one differing in terms of capacity and gate fixing method. The Company markets three types of racks, which are.

7.1) Mod. CFZ (Fig.7).

Galvanised iron rack - 22x22mm section - supplied in 2 - metre lengths - capacity over 2000kg (≈ 20000N). First weld these pieces onto an adequate iron angle bar and then weld the lot to the gate. Besides maintaining the distance between the rack and the side of the gate, the angle bar makes it easy to fix the rack to the gate, even when the latter is subject to slight side slipping. When join welding the various rack pieces, you are advised to arrange a section of rack as in (fig.8) to ensure a correct pitch along the entire length of the rack.

7.2) Mod. CPZ (Fig.7).

Plastic rack - 22x22mm section - supplied in 1- metre lengths - max. capacity 500kg (≈ 5000N). This model is to be fixed to the gate by means of normal or self-threading screws. Also in this case, you are advised to insert a section of rack the other way round in the joint between the various pieces, so as to maintain the correct tooth pitch. This type of rack is quieter and allows height adjustments to be made even after having been fixed, using the slots provided.

7.3) Mod. CVZ (Fig.7)

Galvanised iron rack - 30x12mm section - supplied in 1 - metre lengths - threaded spacers to be welded - max. capacity 2000kg (≈ 20000N). Having fixed the spacers in the middle of each of the slots in the various rack pieces, weld the spacers to the gate. Also in this case, arrange a section of rack the other way round in the joining points of the various rack pieces to ensure a correct tooth pitch. The screws which fix the rack to the spacers allow the rack to be adjusted in height.

7.4) Rack fitting

To fit the rack, proceed as follows:

- Activate the emergency release by rotating the appropriate release knob (See paragraph "Emergency manoeuvre").
- Rest the rack end on the control pinion and secure it (by welding or using screws) in correspondence with the pinion, while sliding the gate along by hand (fig. 9).
- In the case of incorrect gate alignment (excessive side curving) which cannot be corrected, place a few shims between the rack and gate in order to ensure continuous centring of the rack with respect to the pinion (fig. 10).

DANGER - The welding operation is to be carried out by a competent person who must be provided with all the personal protection equipment required by the current safety standards.

8) PINION ADJUSTMENT

Having finished fixing the rack, the rack-pinion play needs to be adjusted to approximately 2mm (fig.6): this is obtained by slackening the four M10 nuts under the gearmotor base by approximately 2mm, and then securing the four upper nuts. Make sure that the rack and pinion are aligned and centred (fig.10).

WARNING - Remember that the rack and pinion life strictly depends on their correct meshing.

9) ELECTROMECHANICAL LIMITING DEVICES

The operation must be carried out with the emergency release activated and the mains power supply disconnected. The runners which control the limiting devices are to be positioned at both ends of the rack.

- Push the gate fully open by hand.
- Position the opening end-of-stroke runner (fig.11) so that it intercepts the microswitch control lever and makes it trigger. Having identified the correct position, tighten the runner screws.
- Push the gate fully closed by hand.
- Position the closing end-of-stroke runner (fig.11) so that it intercepts the microswitch control lever and makes it trigger. Having identified the correct position, tighten the runner screws.
- The runners must lock the gate before this intercepts the mechanical backstops placed on the track. The closing end-of-stroke runner adjustment must be made in such a way as to leave a clearance of approximately 50mm between the gate and the fixed swing leaf, as prescribed by the current safety standards, otherwise fit an electric edge at least 50mm thick (fig.12).

10) GATE BACKSTOPS

DANGER - The gate must be provided with mechanical backstops, both on opening and closing, in order prevent it from coming out of the upper guide (fig.13); the backstops must be tightly secured to the ground, a few centimetres beyond the electrical stop point.

11) ELECTRICAL INSTALLATION SETUP

Lay out the electrical installation as shown in fig.14 with reference to the CEI 64-8 and IEC364 provisions complying with the HD384 and other national standards in force for electrical installation.

WARNING! For connection to the mains, use a multipolar cable having a minimum cross section of 3x1.5 mm² and complying with the current standards. (For example, if the cable is not protected, it must be at least equal to H07 RN-F, whereas if it is protected it must be at least equal to H07 VV-F with a 3x1.5 sq mm² cross section).

Connect the control and safety devices in compliance with the previously mentioned technical installation standards. The cables (mains and auxiliary) must be distinctly separated. Fig. 14 shows the number of connections and their cross sections for a length of approximately 100 metres; for greater lengths, calculate the cross section for the true automation load.

The main automation components are (fig.14):

- I** Type-approved adequately rated omnipolar circuit-breaker with at least 3-mm contact opening, provided with protection against overloads and short circuits, suitable for cutting out automation from the mains. If not already installed, place a type-approved omnipolar circuit-breaker with a 0.03A threshold just before the automation system.
- S** Key selector.
- AL** Blinker with tuned antenna.
- M** Actuator
- P** Wall-mounted pushbutton panel.
- Fte, Fre** Pair of external photocells.
- T** 1-2-4 channel transmitter.

12) TERMINAL BOARD CONNECTIONS

First pass the appropriate electric cables through the raceways and fix the various automation components to the chosen points, then connect them following the directions and diagrams contained in the control unit instruction manual.

Carry out phase, neutral and (compulsory) earth connections.

The mains power supply cables must be stripped as little as possible; the power supply cable earth wire must be stripped for a greater length, in order to reach the terminal purposely arranged in the box (fig. 15 ref. "A").

The cables must be tied by additional fastening next to the terminals, by means of clips for example.

All the operator wiring operations must be carried out by qualified personnel. Operate the automation only after having connected and checked all the safety devices.

A description of the terminals of MIZAR control unit installed on the actuator is given below (fig. 16).

- 1-2 Single-phase power supply: (1=L) (2=N)
- 3-4-5 Motor connection (4 common, 3-5 operation and capacitor)
- 4-1 Blinker connection (mains voltage)
- 7-8 Open-Close push button, key selector (N.O.)
- 7-9 Stop push button (N.C.). If not used, leave jumped.
- 7-10 Photocell input or rubber skirt (N.C.). If not used, leave jumped.
Opening limit switch (N.C.). If not used, leave jumped.
Closing limit switch (N.C.). If not used, leave jumped.
- 13-14 24 V ~ 180mA max output - power supply to photocells or other devices
- 15-16 Second radio channel output of twin-channel receiver board
Antenna input for radio receiver board (17 signal - 18 braid).
- ⊕ GND terminal

WARNING: If the opening direction is not correct, invert the motor connections no. 3 and 5 and connections no. 11 and 12 of the opening and closing limit switches.

13) MOTOR TORQUE SETTING (SAFETY CLUTCH)



WARNING: Check that the impact force value measured at the points established by the EN 12445 standard is lower than that specified in the EN 12453 standard.

The setting must be carried out according to whatever is provided for by the current safety standards. For this purpose, the motor torque needs to be set in the following way:

- Disconnect the mains power supply.
- Remove the screws securing the gearmotor guard.
- Use the fixed key provided to lock the motor shaft (fig. 17 - ref. "A"). Using the release knob, screw the self-locking nut (fig. 17 - ref. "D") to increase the torque, or slacken it to decrease the torque.
- Reconnect the power supply and, with the help of a torquemeter, check that the motion stops at the mechanical resistance values set out by the current standards.
- Put the protection guard back on the gearmotor and secure it with its screws.



DANGER - The torque regulator must be calibrated before the automation system is made to be operational.

14) MANUAL RELEASE

The manual or emergency release is to be activated when a gate must be opened by hand, and in all cases where the automation system fails to operate or operates incorrectly. To carry out the emergency manoeuvre, proceed as follows:

- Insert the standard key into its appropriate seat (fig. 18) and rotate it anticlockwise (90°), then rotate the release knob clockwise along its entire stroke. This way the pinion is made to idle, and therefore allows the gate to be opened by hand.

Warning: Do not push the gate leaf hard, but rather help it along its entire stroke.

- To reset motor-driven control, rotate the knob anticlockwise along its entire stroke, and then rotate the standard key clockwise until it is held tight. Keep the key in a safe place which is known to all the people concerned.

In the case where the release knob is supplied with a personalised key (fig. 18), proceed as follows:

- Insert the personalised key into the lock, rotate the key anticlockwise by 90°.
- Hold the release knob and rotate it clockwise (fig. 18) until it stops.

This way the pinion is made to idle, and therefore allows the gate to be opened by hand.

- Push the gate leaf by hand, helping it along its entire stroke.
The key cannot be taken out of the lock until the knob is brought back to its initial position (motor-driven activation).
- To reset motor-driven control, rotate the knob anticlockwise along its entire stroke, move the key back to its locking position; then take the key out and keep it in a safe place which is known to all the people concerned.

15) INSTALLATION CHECK

Before the automation device finally becomes operational, scrupulously check the following conditions:

- Check that all the safety devices (limit microswitches, photocells, electric edges etc) operate correctly.
- Check that the rack and pinion are correctly meshed (minimum play 2mm).
- Check that the pushing force of the gate is within the limits provided for by the current standards.
- Check that the opening and closing end-of-stroke runners are correctly positioned and tightly secured.
- Check the starting and stopping operations using the manual control.
- Check the starting and stopping operations using the remote radio control.
- Check the normal or customised operation logic.

16) AUTOMATION DEVICE USE

Since the automation device can be controlled both remotely and in sight, by means of a radio control device or a button, all the safety devices must be frequently checked in order to ensure their perfect efficiency.

WARNING! In the event of any safety device malfunction, request immediate assistance from qualified personnel. Children must be kept at a safe distance from the automation operation area.

17) AUTOMATION CONTROL

The use of this control device allows the gate to be opened and closed automatically. There are different types of controls (manual, radio control, magnetic card access etc.) depending on the installation requirements and characteristics. For the various control systems, see the relevant instructions. **The installer undertakes to instruct the user about correct automation operation, also pointing out the actions to be taken in case of emergency.**

18) MAINTENANCE

WARNING! Before proceeding to any maintenance, disconnect the mains power supply and, if the battery is fitted, one of its poles.

These are the check and maintenance operations to be carried out:

- Check the condition of lubrication of the metal racks once a year.
- Keep the sliding track always clean and free from debris.
- Occasionally clean the photocell optical elements.
- Have a qualified technician (installer) check the correct torque limit setting. When any operational malfunction is found, and not resolved, disconnect the mains power supply and request the assistance of a qualified technician (installer). When the automation controller is out of service, you can activate the manual release device (see paragraph on "Emergency manoeuvre") in order to set the pinion idling and therefore allow the gate to be opened and closed by hand.

19) NOISE

The environmental noise produced by the gear-motor in normal operation conditions is constant and does not exceed 70 dB (A).

21) SCRAPPING

Materials must be disposed of in conformity with the current regulations. In case of scrapping, the automation devices do not entail any particular risks or danger. In case of materials to be recycled, these should be sorted out by type (electrical components, batteries, copper, aluminium, plastic etc.).

20) DISMANTLING

When the automation system is disassembled to be reassembled on another site, proceed as follows:

- Disconnect the power supply and the entire external electrical installation.
- In the case where some of the components cannot be removed or are damaged, they must be replaced.

21) MALFUNCTION: CAUSES and REMEDIES

21.1) The gate does not open. The motor does not turn.

- 1) Check that the photocells or the sensitive edges are not dirty, engaged, or not aligned. Proceed accordingly.
- 2) Check that the electronic appliance is correctly supplied. Check the

integrity of the fuses.

- 3) Check that the functions are correct by means of the control unit diagnosing LEDs (see relevant instructions).

Identify causes for faults, if any. If the LEDs show persisting start control, check that no radio controls, start buttons or other control devices keep the start contact activated (closed).

- 4) If the control unit does not work, it must be replaced.
If after having carried out the checks listed above the problem persists, replace the actuator.

21.2) The gate does not open. The motor turns but the movement does not take place.

- 1) The manual release is activated. Reset the power-driven operation.
- 2) Check that the gate had reached the mechanical end-of-stroke stops. Release and move the gate manually, and reset the power-driven control. Check and correct the end-of-stroke bracket position.
- 3) Check that the mechanical setting of the gate is not defective, for example if the wheels are blocked or the rack is not aligned with the pinion, etc.
- 4) Check that the clutch does not slip. If it does, load it as described in the relevant paragraph.
If after having carried out the checks listed above the problem persists, replace the actuator.

WARNING! Correct controller operation is only ensured when the data contained in the present manual are observed. The company is not to be held responsible for any damage resulting from failure to observe the standards relating to safety, installation and good technical practice, as well as the instructions contained in the present manual.

The descriptions and illustrations contained in the present manual are not binding. The Company reserves the right to make any alterations deemed appropriate for the technical, manufacturing and commercial improvement of the product, while leaving the essential product features unchanged, at any time and without undertaking to update the present publication.

Fig. 1

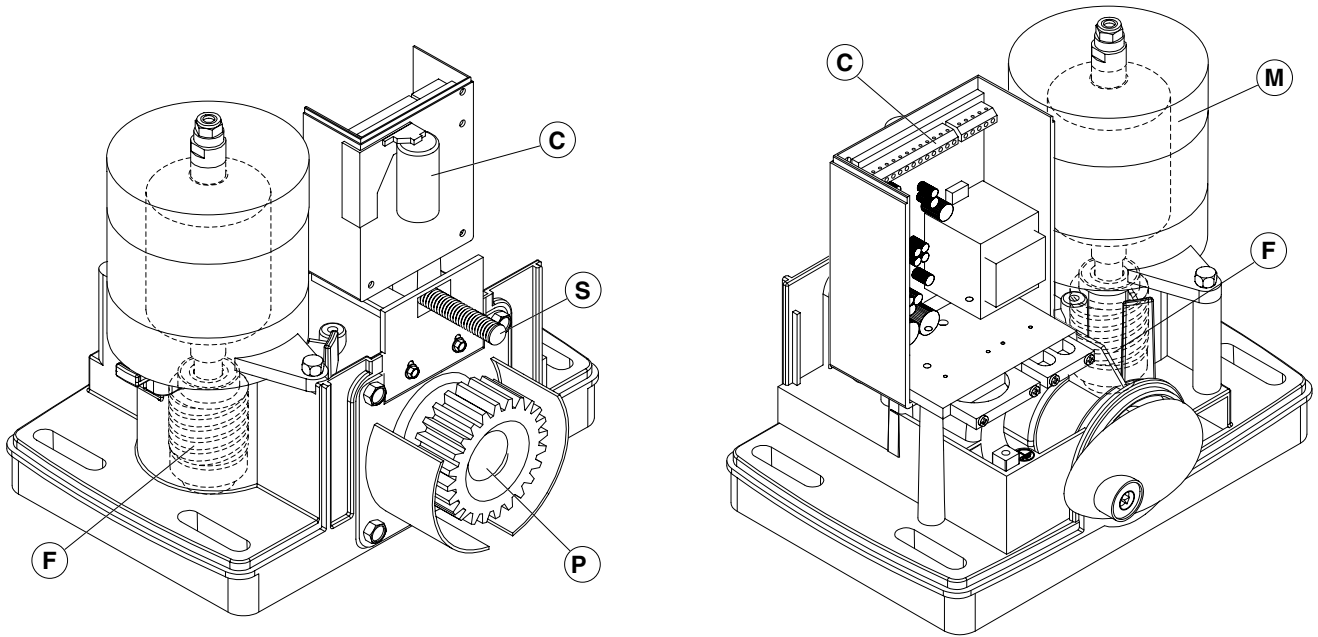

Fig. 2

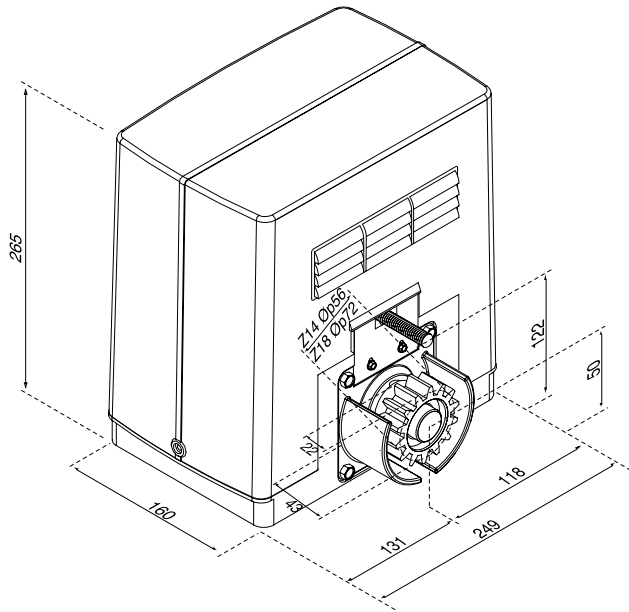

Fig. 4

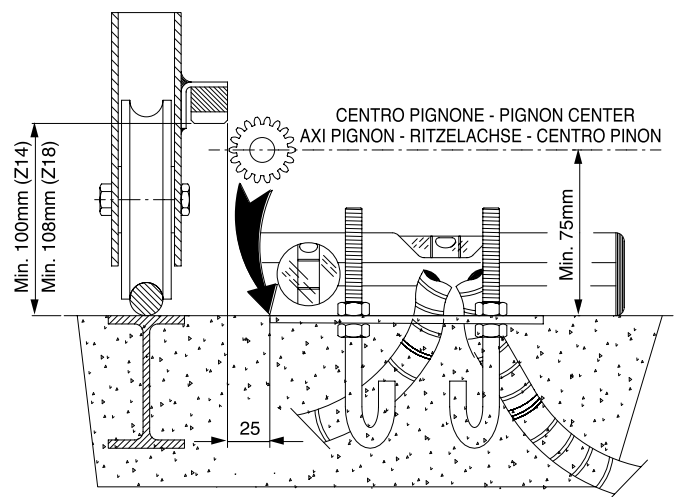

Fig. 3

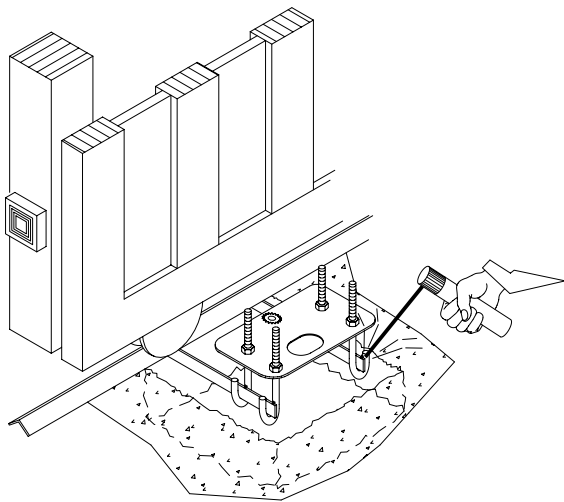

Fig. 5

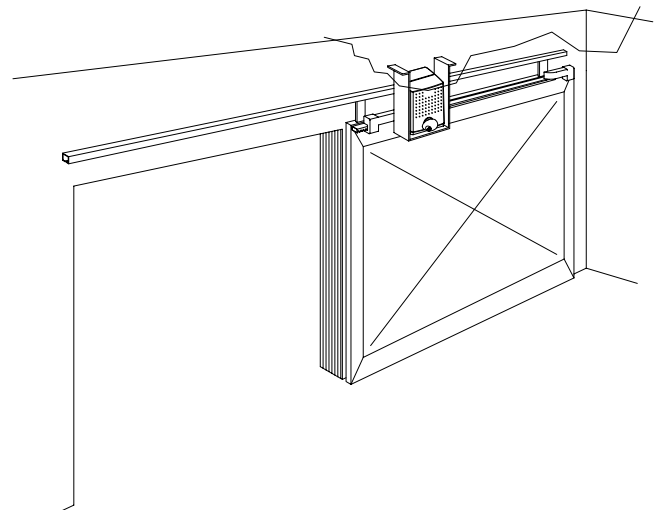

Fig. 6

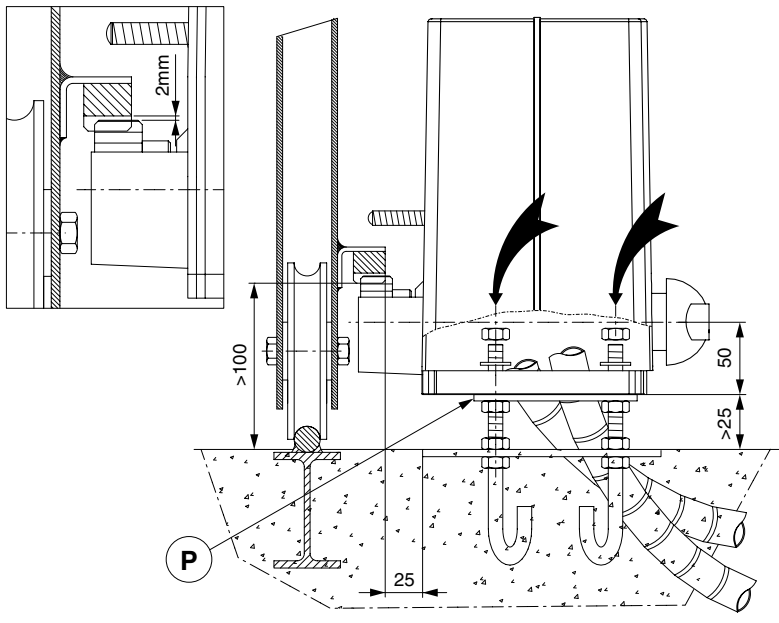

Fig. 7

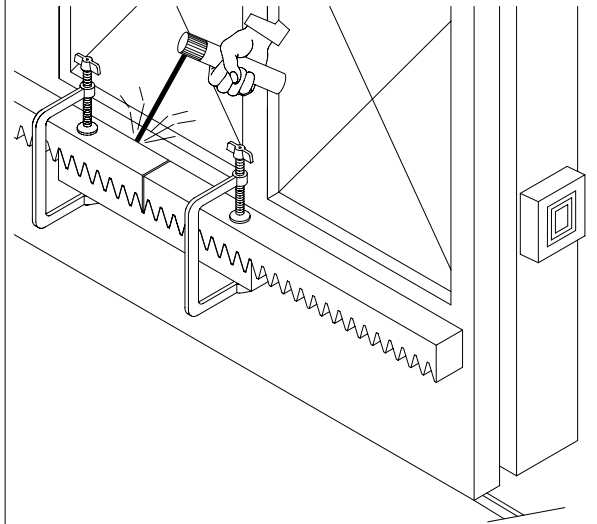

Fig. 8

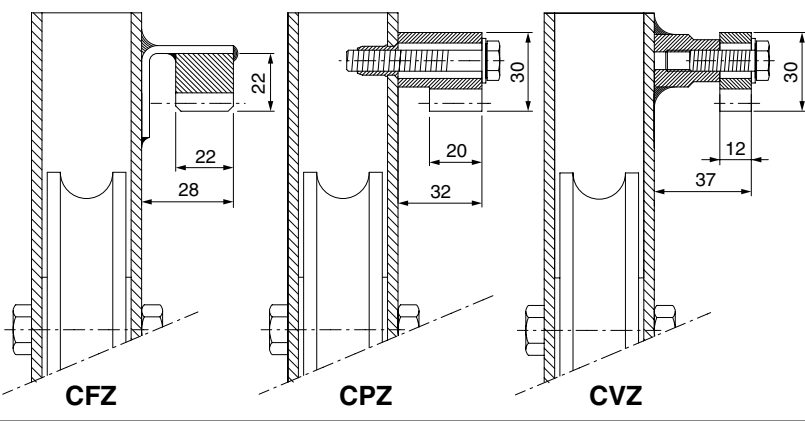

Fig. 9

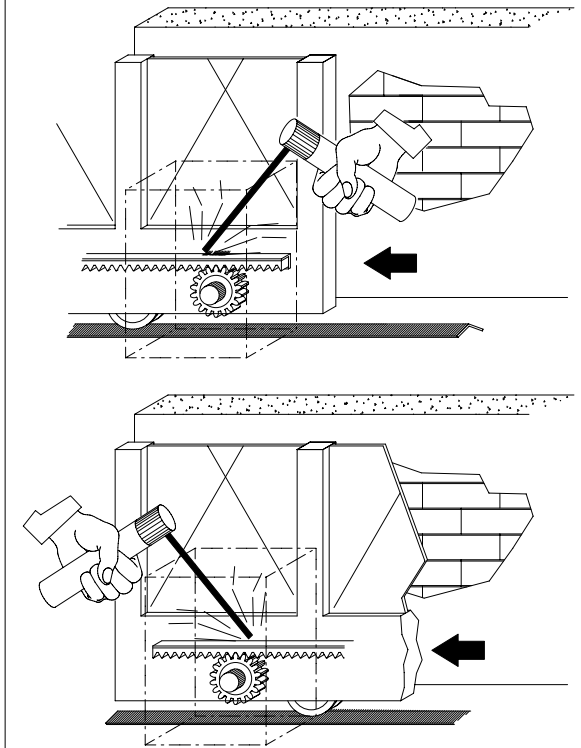

Fig. 10

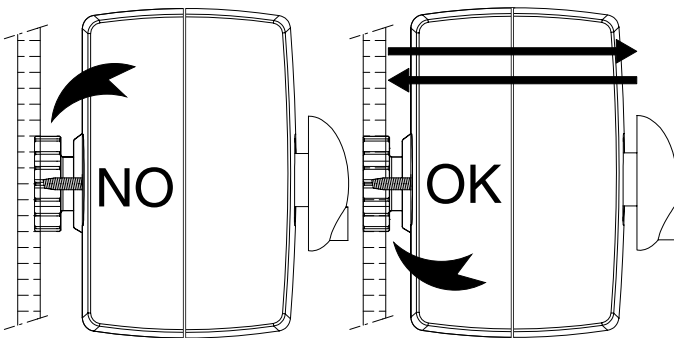

Fig. 11

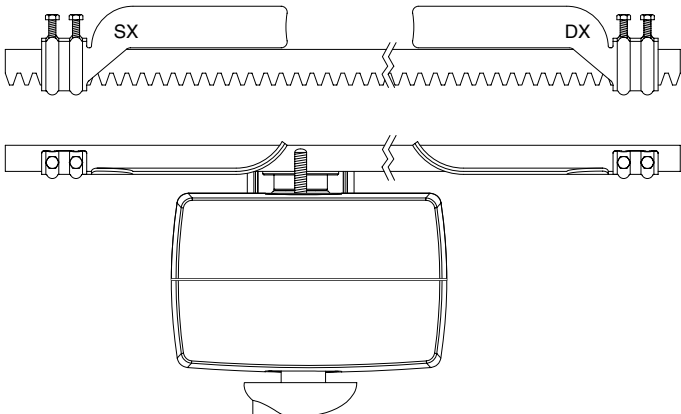

Fig. 12

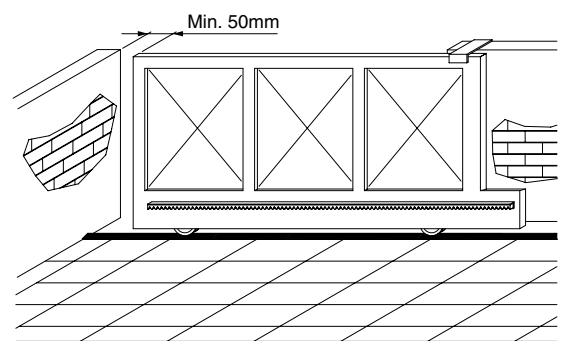
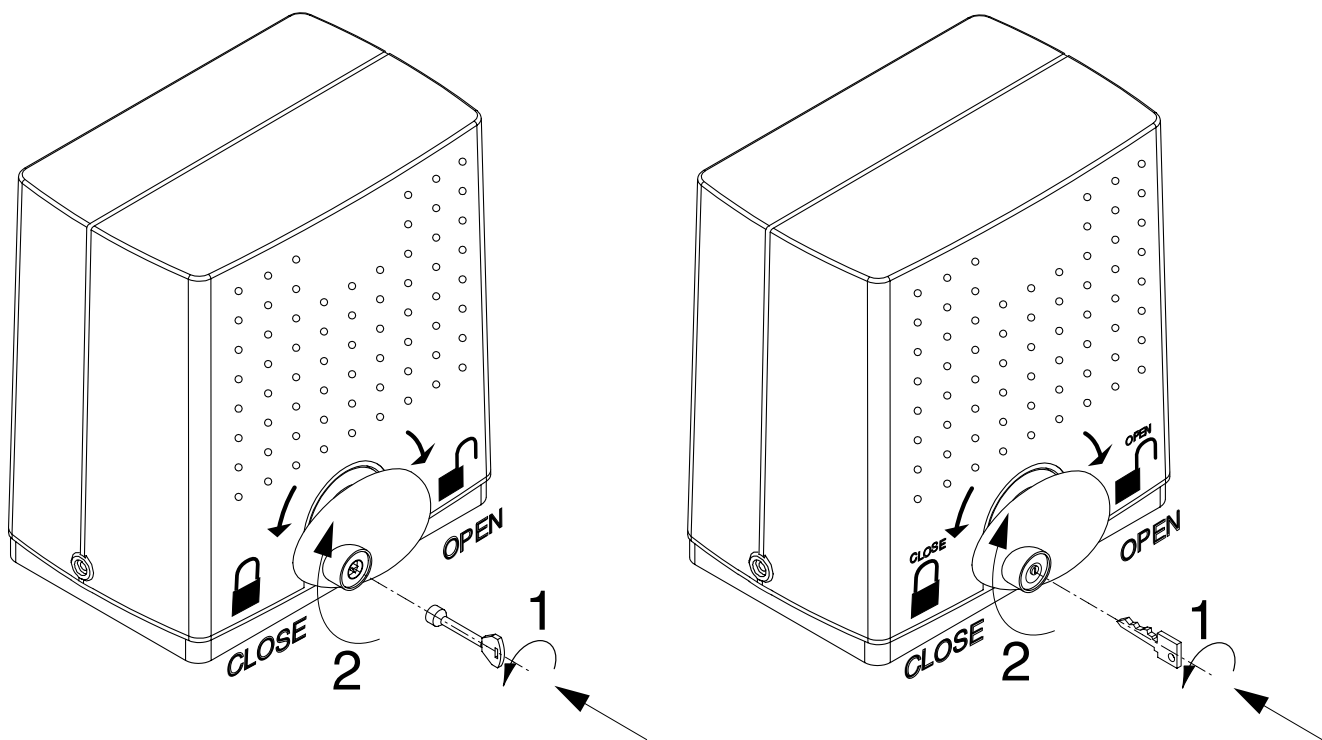

Fig. 20

D811299_05



BFT FRANCE
 Parc Club des Aygalades
 35 bd capitaine GEZE
 13333 MARSEILLE Cedex 14

Tel. 0491101860
 Fax 0491101866

BFT DEUTSCHLAND
 Vertretung und Lager
 Johannisstr. 14,D-90763 Fürth

Tel. 0049 911 773323
 Fax 0049 911 773324

BFT S.p.a. ITALIA

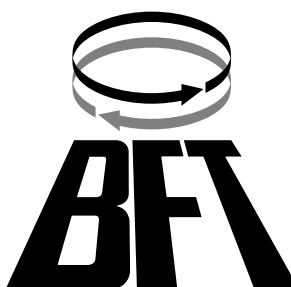

Via Lago di Vico, 44
 36015 Schio (VI)
 Tel.naz. 0445 696511
 Tel.int. +39 0445 696533
 Fax 0445 696522
 Internet: www.bft.it
 E-mail: sales@bft.it