

**LOW-VOLTAGE
AUTOMATION FOR
RACK SLIDING
GATES**



Thank you for buying this product, our company is sure that you will be more than satisfied with the product's performance. The product is supplied with a "Warnings" leaflet and an "Instruction booklet". These should both be read carefully as they provide important information about safety, installation, operation and maintenance. This product complies with the recognised technical standards and safety regulations. We declare that this product is in conformity with the following European Directives: 89/336/EEC and 73/23/EEC (and subsequent amendments).

1) GENERAL OUTLINE

The **DEIMOS BT** actuator offers ample installation versatility thanks to its compactness, the extremely low position of its pinion as well as the height and depth adjustments available. The adjustable electronic torque limiter ensures antisquash safety. The emergency manual manoeuvre can be activated very easily by means of a knob. The end-of-run stop is controlled by electromechanical limit microswitches. The control unit is incorporated. The gearmotor (fig.1) comprises:

- M** Motor.
- R** Reduction gear with worm screw and wheel.
- F** Electromechanical limit switch unit.
- P** Pinion.
- S** Release mechanism.
- QSC** Control unit.

The following optional accessories are available:

- SBBAT mod. Buffer battery kit

It can be incorporated into the actuator and allows the automation system to operate even when the mains power supply is disconnected for a short time. The pack includes (fig.1):

- 2 buffer batteries (ref. B).
- 1 battery holder base (ref. BB).
- 1 battery charger board (ref. SBS).
- Assembly instruction manual.
- Various bolts, screws and cables.

- MSC mod. Release knob (fig.20)

Fixed release knob with personalised key.

2) GENERAL SAFETY

WARNING! An incorrect installation or improper use of the product can cause damage to persons, animals or things.

- The "Warnings" leaflet and "Instruction booklet" supplied with this product should be read carefully as they provide important information about safety, installation, use and maintenance.
- Scrap packing materials (plastic, cardboard, polystyrene etc) according to the provisions set out by current standards. Keep nylon or polystyrene bags out of children's reach.
- Keep the instructions together with the technical brochure for future reference.
- This product was exclusively designed and manufactured for the use specified in the present documentation. Any other use not specified in this documentation could damage the product and be dangerous.
- The Company declines all responsibility for any consequences resulting from improper use of the product, or use which is different from that expected and specified in the present documentation.
- Do not install the product in explosive atmosphere.
- The construction components of this product must comply with the following European Directives: 89/336/CEE, 73/23/EEC and subsequent amendments. As for all non-EEC countries, the above-mentioned standards as well as the current national standards should be respected in order to achieve a good safety level.
- The Company declines all responsibility for any consequences resulting from failure to observe Good Technical Practice when constructing closing structures (door, gates etc.), as well as from any deformation which might occur during use.
- The installation must comply with the provisions set out by the following European Directives: 89/336/CEE, 73/23/EEC, 98/37/EEC and subsequent amendments.
- Disconnect the electrical power supply before carrying out any work on the installation. Also disconnect any buffer batteries, if fitted.
- Fit an omnipolar or magnetothermal switch on the mains power supply, having a contact opening distance equal to or greater than 3mm.
- Check that a differential switch with a 0.03A threshold is fitted just before the power supply mains.
- Check that earthing is carried out correctly: connect all metal parts for closure (doors, gates etc.) and all system components provided with an earth terminal.
- Fit all the safety devices (photocells, electric edges etc.) which are needed to protect the area from any danger caused by squashing, conveying and shearing.

- Position at least one luminous signal indication device (blinker) where it can be easily seen, and fix a Warning sign to the structure.
- The Company declines all responsibility with respect to the automation safety and correct operation when other manufacturers' components are used.
- Only use original parts for any maintenance or repair operation.
- Do not modify the automation components, unless explicitly authorised by the company.
- Instruct the product user about the control systems provided and the manual opening operation in case of emergency.
- Do not allow persons or children to remain in the automation operation area.
- Keep radio control or other control devices out of children's reach, in order to avoid unintentional automation activation.
- The user must avoid any attempt to carry out work or repair on the automation system, and always request the assistance of qualified personnel.
- Anything which is not expressly provided for in the present instructions, is not allowed.

3) TECHNICAL DATA

3.1) DEIMOS BT Actuator

Power supply:	single-phase 230V ±10% 50Hz (*)
Motor:	24Vdc
Motor revolutions:	3500min ⁻¹
Absorbed power:	70W
Max absorbed power:	0,5A (230Vac) - 1A (110Vac)
Reduction ratio:	1/44
Output revolutions:	79min ⁻¹
Pinion pitch:	4mm (14 teeth)
Leaf speed:	12m/min
Max leaf weight:	3000N (≈300kg)
Max torque:	9Nm
Impact reaction:	Electronic torque limiter
Lubrication:	Permanent grease
Manual manoeuvre:	Mechanical knob release
No. manoeuvres in 24 hours:	30
Control unit:	incorporated
Buffer batteries (optional):	2 batteries 12V 1.2Ah
Environmental conditions:	from -15°C to +40°C
Degree of protection:	IP24
Noise:	< 70dBA
Controller weight:	7kg (≈70N)
Dimensions:	See fig.2

(*) Special supply voltages on request.

3.2) QSC-433 Control unit technical data (Fig.17)

Supply to accessories:	24Vac (1A max)
Ampere-stop setting:	on closing and opening
Automatic closing time:	from 1 to 120s
Working time:	from 1 to 60s
Pedestrian opening time:	5s fixed
Reverse pause:	approx. 1s
Blinker connection:	24V max 25W
Fuses:	See fig.17
Parameter and option setting:	by means of keys or UNIPRO
Incorporated Rolling-Code radio receiver:	frequency 433.92MHz
Coded by means of :	Rolling-Code Algorithm
No. combinations:	4 milliard
Antenna impedance:	50Ohm (RG58)
Max no. radio controls to be memorised:	64

3.3) Transmitter MITTO

Keys:	Yellow
Power supply:	Two 3V lithium batteries (type CR2016)
Range:	50 / 100 metres
Transmitter versions: MITTO2 - double-channel, MITTO4 - four-channel.

3.4) Transmitter

Key colour:	Red
Power supply:	12V Alkaline Battery
Range:	50 - 100 metres
Working temperature:	-20°C to +55°C
Transmitter versions:	

TRC1-Single-Channel. **TRC2**-Double -Channel **TRC4**-Four-Channel.

4) PRELIMINARY CHECKS

Before proceeding to any installation work, check that the gate structure conforms to whatever is prescribed by the current standards, and in particular that:

- The gate sliding track is linear and horizontal, and the wheels are suitable for supporting the gate weight.
- The gate manual operation can be carried out smoothly along its entire run, and there is no excessive side slipping.
- A correct play is provided between the upper guide and the gate to ensure regular noiseless movement.
- The opening and closing gate stops are positioned.
- The established position for gearmotor fixing allows the emergency elements checked do not meet the above requirements, proceed to carrying out the necessary corrective actions or replacements.

WARNING: Remember that control devices are intended to facilitate gate operation, but can not solve problems due to any defects or deficiency resulting from failure to carry out correct installation or maintenance. Take the product out of its packing and inspect it for damage. Should it be damaged, contact your dealer. Remember to dispose of its components (cardboard, polystyrene, nylon, etc.) according to the current prescriptions.

5) BASE PLATE ANCHORING

5.1) Standard position

- Dig a hole where the cement pad with the buried base plate log bolts is to be placed in order to fix the reduction gear unit (fig.3). If the sliding track is already there, digging must be partly carried out in the track foundation casting. This way, should the track foundation casting sag, the gearmotor base would also lower, thus maintaining the play between pinion and rack (approximately 1-2 mm).
- Position the base plate according to the dimensions specified in fig.4.
- The pinion symbol printed on the base plate must be visible and directed towards the gate. This also ensures the correct positioning of the raceways for electrical connections.
- Let the flexible pipes containing electrical cables protrude from the base plate.
- In order to keep the base plate in its correct position during installation, it may be useful to weld two iron flat bars under the track, and then weld the log bolts onto them (fig.3).
- Make a concrete casting in such a way as to embody the base plate casting into that of the gate track.
- Accurately check that:
 - The positioning dimensions are correct.
 - That the base plate is well levelled.
 - That the 4 stud threads are well clear of cement.
 - Let the casting harden.

5.2) Other positions

The gearmotor can be positioned in different ways. As an example, fig.5 illustrates a particular type of installation. In the case where the gearmotor is not fixed on the level of the sliding track (**Standard position**), you must ensure that the gearmotor is tightly secured also in relation to the gate position, so as to maintain a correct play (1-2mm) between rack and pinion. The current safety standards with respect to persons, animals and things must be strictly observed, and in particular risks of accidents due to squashing in the area of pinion-rack meshing, as well as other mechanical risks, must be carefully avoided. **All the critical spots must be protected by safety devices in compliance with the current prescriptions.**

6) GEARMOTOR FIXING

When the casting has hardened, observe fig. 6 and proceed as follows:

- Position an M10 nut on each of the tie rods, keeping a distance of at least 25mm from the base to allow the gearmotor to be lowered after the installation is completed, or for subsequent adjustments of the play between pinion and rack.
- Position a plate "P" supplied as standard on each pair of tie rods and, with the help of a level, adjust the plane in both directions.
- Remove the cover and screw-cover guard from the gearmotor, and position the reduction gear unit on the four tie rods with the pinion facing the gate.
- Position the four washers and screw the four gearmotor locking bolts.
- Adjust the depth of the gearmotor, making it slide in the appropriate slots found in the base, and fix it at a distance between pinion and gate which is adequate to the type of rack to be installed. The rack teeth must mesh into the pinion along their entire width. In the paragraph headed "**Rack fitting**" we specify the measurements and installation methods of the most widely used types of rack.

7) RACK FITTING

A rack having a 4 tooth pitch must be fitted to the gate. As far as the length is concerned, this must include the passage space, as well as the space for securing the brackets activating the limit microswitches, and for the pinion meshing section. There are different types of rack, each one differing in terms of capacity and gate fixing method. The Company markets three types of racks, which are.

7.1) Mod. CFZ (Fig.8).

Galvanised iron rack - 22x22mm section - supplied in 2 - metre lengths - capacity over 2000kg (\approx 20000N). First weld these pieces onto an adequate iron angle bar and then weld the lot to the gate. Besides maintaining the distance between the rack and the side of the gate, the angle bar makes it easy to fix the rack to the gate, even when the latter is subject to slight side slipping. When join welding the various rack pieces, you are advised to arrange a section of rack as in (fig.7) to ensure a correct pitch along the entire length of the rack.

7.2) Mod. CPZ (Fig.8).

Plastic rack - 22x22mm section - supplied in 1- metre lengths - max. capacity 500kg (\approx 5000N). This model is to be fixed to the gate by means of normal or self-threading screws. Also in this case, you are advised to insert a section of rack the other way round in the joint between the various pieces, so as to maintain the correct tooth pitch. This type of rack is quieter and allows height adjustments to be made even after having been fixed, using the slots provided.

7.3) Mod. CVZ (Fig.8)

Galvanised iron rack - 30x12mm section - supplied in 1 - metre lengths - threaded spacers to be welded - max. capacity 2000kg (\approx 20000N). Having fixed the spacers in the middle of each of the slots in the various rack pieces, weld the spacers to the gate. Also in this case, arrange a section of rack the other way round in the joining points of the various rack pieces to ensure a correct tooth pitch. The screws which fix the rack to the spacers allow the rack to be adjusted in height.

7.4) Rack fitting

To fit the rack, proceed as follows:

- Activate the emergency release by rotating the appropriate release knob (See paragraph "Emergency manoeuvre").
- Rest the rack end on the control pinion and secure it (by welding or using screws) in correspondence with the pinion, while sliding the gate along by hand (fig. 9).
- In the case of incorrect gate alignment (excessive side curving) which cannot be corrected, place a few shims between the rack and gate in order to ensure continuous centring of the rack with respect to the pinion (fig. 10).

DANGER - The welding operation is to be carried out by a competent person who must be provided with all the personal protection equipment required by the current safety standards.

8) PINION ADJUSTMENT

Having finished fixing the rack, the rack-pinion play needs to be adjusted to approximately 2mm (fig.6): this is obtained by slackening the four M10 nuts under the gearmotor base by approximately 2mm, and then securing the four upper nuts. Make sure that the rack and pinion are aligned and centred (fig.10).

WARNING - Remember that the rack and pinion life strictly depends on their correct meshing.

9) ELECTROMECHANICAL LIMITING DEVICES

The operation must be carried out with the emergency release activated and the mains power supply disconnected. The runners which control the limiting devices are to be positioned at both ends of the rack.

- Push the gate fully open by hand.
- Position the opening end-of-stroke runner (fig. 11) so that it intercepts the microswitch control lever and makes it trigger. Having identified the correct position, tighten the runner screws.
- Push the gate fully closed by hand.
- Position the closing end-of-stroke runner (fig.11) so that it intercepts the microswitch control lever and makes it trigger. Having identified the correct position, tighten the runner screws.
- The runners must lock the gate before this intercepts the mechanical backstops placed on the track. The closing end-of-stroke runner adjustment must be made in such a way as to leave a clearance of approximately 50mm between the gate and the fixed swing leaf, as prescribed by the current safety standards, otherwise fit an electric edge at least 50mm thick (fig.12).

10) GATE BACKSTOPS

DANGER - The gate must be provided with mechanical backstops, both on opening and closing, in order prevent it from coming out of the upper guide (fig.13); the backstops must be tightly secured to the ground, a few centimetres beyond the electrical stop point.

11) ELECTRICAL INSTALLATION SETUP

Lay out the electrical installation as shown in fig.14 with reference to the CEI 64-8 and IEC364 provisions complying with the HD384 and other national standards in force for electrical installation.

WARNING! For connection to the mains, use a multipolar cable having a minimum cross section of 3x1.5 mm² and complying with the current standards. (For example, if the cable is not protected, it must be at least equal to H07 RN-F, whereas if it is protected it must be at least equal to H07 VV-F with a 3x1.5 sq mm² cross section).

Connect the control and safety devices in compliance with the previously mentioned technical installation standards. The cables (mains and auxiliary) must be distinctly separated. Fig. 14 shows the number of connections and their cross sections for a length of approximately 100 metres; for greater lengths, calculate the cross section for the true automation load.

The main automation components are (fig.14):

I	Type-approved adequately rated omnipolar circuit-breaker with at least 3-mm contact opening, provided with protection against overloads and short circuits, suitable for cutting out automation from the mains. If not already installed, place a type-approved omnipolar circuit-breaker with a 0.03A threshold just before the automation system.
QR	Control panel with built-in receiver
S	Key selector.
AL	Blinker with tuned antenna.
M	Actuator
P	Wall-mounted pushbutton panel.
Fte, Fre	Pair of external photocells.
T	1-2-4 channel transmitter.

12) TERMINAL CONNECTIONS

After adequate electric cables have been made to pass through the raceways and the various automation components fixed to the chosen points, these must be connected according to the instructions and diagrams shown in the relevant instruction manuals. Connect the phase, neutral and earth (compulsory) cables. The mains cable is to be secured in the appropriate cable clamp (fig.15 - ref. P1), the accessory cables in their cable clamp (fig.15 - ref. P2), and the protection (earth) wire, having a yellow/green insulating sheath, must be held in its appropriate wire clamp (fig.15 - ref. S). The automation device is to be set at work after all the safety devices have been connected and checked. See the terminal diagram in fig.16.

JP1

- 1-2 Motor connection (1 Light Blue - 2 Red).
- 3-4 Secondary transformer connection 24V.

WARNING - If the opening direction is not correct, reverse connections 1 and 2 of the motor and connections 7 and 8 of the opening and closing limit switches.

JP2

- 6-7 Closing limit switch SWC (6 Black common - 7 Red).
- 6-8 Opening limit switch SWO (6 Black common - 8 Brown).
- 9-10 Blinker 24V max 25W.

JP3

- 11-12 Antenna (11 signal, 12 braid).
 - 13-14 Supply to accessories 24Vac/dc (13+, 14-).
 - 15-16 Free contact (N.O.).
- Gate-Open Warning light **SCA** (24Vac max 3W) or 2nd Radio channel output. This option can be set from "menu B" (see programming page).

JP4

- 20-21 **PED** Pedestrian control button (N.O.) Opens the gate for a time of 8 seconds according to the set logic modes (2 or 4 steps).

JP5

- 22-23 **START** button and key selector (N.O.).
- 22-24 **STOP** button (N.C.). In all cases, it stops automation until a new start command is given. If not used, leave bridged.
- 22-25 **PHOT** Electric edge photocell input (N.C.). If not used, leave bridged.

JP6

- 28-29 Primary transformer connection 230Vac.
- 30-31 Single-phase supply 230Vac, 50/60Hz (30N-31L).

13) MANUAL PROGRAMMING OF CONTROL UNIT

13.1) TRIMMER SETTING (Fig.17)

WARNING! Before any setting is made, close jumper JP1.

Set the trimmers to the required value, taking into account that the quantity set increases as the relevant trimmer is rotated clockwise.

WARNING! The values set by the trimmers must be memorised.

This operation can be carried out in 2 ways:

- a) Disconnect and reconnect the mains supply (reset) after each trimmer correction. At the end of the setting, wait at least 5 seconds after the system has been newly supplied before opening jumper JP1.
- b) Enter "Menu A" after setting the trimmers (Simultaneously press SW1 and SW2 once). Check that the LEDs blink according to "Menu A" (the Green LED blinks constantly). After each trimmer correction, enter "Menu A" to memorise the newly set value.

AMPC-AMPO) Torque limiters. These set antisquash sensitivity both during opening and closing manoeuvres. The pushing force at the edge of the leaf must not exceed the maximum limit provided for by the current standards.



WARNING: Check that the value of the impact force, measured at the point s specified by the EN 12445 standard, is lower than that indicated in the EN 12453 standard.

WARNING! Excessive value setting can jeopardise antisquash safety. Setting must be calibrated to the minimum value needed to carry out complete opening and closing strokes. **DANGER** - Before the automation system becomes operational, use a dynamometer to check the value of the pushing force at the edge of the leaf.

AMPC) Sets the closing antisquash trigger current. When it is triggered, it stops the leaf movement and reverses the direction.

AMPO) Sets the opening antisquash trigger current. When it is triggered, it stops the leaf movement.

TCA) Sets the dwell time after which the gate is automatically closed.

TW) Sets the motor operation time, after which the motors stop. The value set must be slightly greater than the time needed to close the gate.

13.2) Setting of programmable parameters and functions

To program the required functions, closely follow the sequence described in the "PROGRAMMING" pages. These include a "LEGEND" which explains the types of signal indications provided by the green and red leds. For "Menu B", the on/off condition is specified for each individual function.

N.B. To enable function setting or modification, you must close jumper J1 (fig.17). Programming is divided into three menus:

- A) Radio control storage.
- B) Function logic setting.
- C) Memory cancellation.

To gain access to each individual programming menu, simultaneously press keys SW1 and SW2 for a short time, and precisely: once for menu A, twice for menu B and three times for menu C. If you do not make any selection within a working time of 60 seconds after entering the programming mode, you will automatically exit programming. When setting is completed, set J1 to Off (open the jumper). **To initialise the control unit with the required setting, disconnect the mains supply for a few seconds, and then reconnect it.**

13.3) Transmitter storage

See the "Menu A" diagram shown on the "PROGRAMMING" page.

13.4) Function logic setting

See the "Menu B" diagram shown on the "PROGRAMMING" page. The red LED (DL1) condition (on/off) shows the function selected. The value given within square brackets [] is the value predefined by the manufacturer. Here follows a detailed explanation of "Menu B" programmable functions:

Opening photocell [Red LED Off]

Red DL1 on: when obscured, it excludes photocell operation on opening. Immediately reverses during the closing phase.

Red DL1 off: when obscured, the photocells remain active during both opening and closing. If the photocell is obscured during closing, it only reverses the movement after the photocell has been disengaged.

Opening impulse blocking [Red LED Off]

Red DL1 on: the start impulse has no effect during the opening phase. Red DL1 off: accepts start commands during opening.

Automatic closing [Red LED On]

Red DL1 on: activates automatic gate closing after a dwell time set by trimmer TCA.

Red DL1 off: excludes automatic closing.

4 or 2 step logic [Red LED Off]

Red DL1 on: **2 step logic**. A start impulse has the following effects
 gate closed: opens
 on opening: stops and activates TCA, if set
 gate open: closes
 on closing: opens
 after stopping: opens
 Red DL1 off: **4 step logic**. A start impulse has the following effects
 gate closed: opens
 on opening: stops and activates TCA, if set
 gate open: closes
 on closing: locks (stops and does not activate TCA)
 after stopping: opens

Gate-open or 2nd radio channel warning light [Red LED On]

Red DL1 on: operation as gate-open warning light (fig.16). This warning light is off when the gate is closed, blinks when it is closing and stays on when the gate is open or being opened.

Red DL1 off: operation as 2nd radio channel (fig.16). Allows other devices to be controlled through the second radio channel of the receiver.

13.5) Cancellation storage

See the "Menu C" diagram shown on the "PROGRAMMING" page.

14) UNIPRO UNIVERSAL PROGRAMMER (Fig.18/19)

The QSC control unit can be programmed by means of the UNIPRO programmer in the following modes:

- TRC/MITTO series radio control programming.
- Function logic programming.
- Memory cancellation.
- Parameter reading.

For the programming procedure, refer to the appropriate UNIPRO instruction manual. Connect the UNIPRO programmer to the TRC/MITTO transmitter use UNITRC/UNIMITTO and UNIFLAT accessories supplied. Connect the UNIPRO programmer to the QSC control unit by means of the UNIDA and UNIFLAT accessories supplied. **N.B.: The QSC control unit cannot supply the UNIPRO programmer.**

15) MANUAL RELEASE

The manual or emergency release is to be activated when a gate must be opened by hand, and in all cases where the automation system fails to operate or operates incorrectly. To carry out the emergency manoeuvre, proceed as follows:

- Insert the standard key into its appropriate seat (fig. 20) and rotate it anticlockwise (90°), then rotate the release knob clockwise along its entire stroke. This way the pinion is made to idle, and therefore allows the gate to be opened by hand.

Warning: Do not push the gate leaf hard, but rather help it along its entire stroke.

- To reset motor-driven control, rotate the knob anticlockwise along its entire stroke, and then rotate the standard key clockwise until it is held tight. Keep the key in a safe place which is known to all the people concerned.

In the case where the release knob is supplied with a personalised key (fig. 20), proceed as follows:

- Insert the personalised key into the lock, rotate the key anticlockwise by 90°.
- Hold the release knob and rotate it clockwise (fig. 20) until it stops. This way the pinion is made to idle, and therefore allows the gate to be opened by hand.
- Push the gate leaf by hand, helping it along its entire stroke.
The key cannot be taken out of the lock until the knob is brought back to its initial position (motor-driven activation).
- To reset motor-driven control, rotate the knob anticlockwise along its entire stroke, move the key back to its locking position; then take the key out and keep it in a safe place which is known to all the people concerned.

16) INSTALLATION CHECK

Before the automation device finally becomes operational, scrupulously check the following conditions:

- Check that all the safety devices (limit microswitches, photocells, electric edges etc) operate correctly.
- Check that the rack and pinion are correctly meshed (minimum play 2mm).
- Check that the pushing force of the gate is within the limits provided for by the current standards.
- Check that the opening and closing end-of-stroke runners are correctly positioned and tightly secured.
- Check the starting and stopping operations using the manual control.
- Check the starting and stopping operations using the remote radio control.
- Check the normal or customised operation logic.

17) AUTOMATION DEVICE USE

Since the automation device can be controlled both remotely and in sight, by means of a radio control device or a button, all the safety devices must be frequently checked in order to ensure their perfect efficiency.

WARNING! In the event of any safety device malfunction, request immediate assistance from qualified personnel. Children must be kept at a safe distance from the automation operation area.

The installer undertakes to instruct the user about correct automation operation, also pointing out the actions to be taken in case of emergency.

18) AUTOMATION CONTROL

The use of this control device allows the gate to be opened and closed automatically. There are different types of controls (manual, radio control, magnetic card access etc.) depending on the installation requirements and characteristics. For the various control systems, see the relevant instructions.

19) MAINTENANCE

WARNING! Before proceeding to any maintenance, disconnect the mains power supply and, if the battery is fitted, one of its poles.

These are the check and maintenance operations to be carried out:

- Check the condition of lubrication of the metal racks once a year.
- Keep the sliding track always clean and free from debris.
- Occasionally clean the photocell optical elements.
- Have a qualified technician (installer) check the correct torque limit setting.

When any operational malfunction is found, and not resolved, disconnect the mains power supply and request the assistance of a qualified technician (installer). When the automation controller is out of service, you can activate the manual release device (see paragraph on "Emergency manoeuvre") in order to set the pinion idling and therefore allow the gate to be opened and closed by hand.

20) MALFUNCTIONS AND REMEDIES

20.1) Faulty actuator operation

- Use an appropriate instrument to check that the actuator ends are supplied with voltage after the opening or closing command.
- If the leaf movement is opposite to that required, reverse the motor drive connections in the control unit.
- Leaf stop: when the working time is insufficient, the leaf may not complete its stroke. Slightly increase the working time in the control unit.

20.2) Faulty operation of electrical accessories

In case of fault, all the control and safety devices can cause the automation controller to malfunction or lock. If the control unit is provided with self-diagnosing facility, identify the fault. If a fault is found, it is advisable to disconnect and, if necessary, bridge, all the automation control devices one by one, until the one causing the fault is identified. Replace or repair it, then reset all the devices which were previously disconnected or bridged. For all the devices installed, make reference to the respective instruction manual.

21) SCRAPPING

Materials must be disposed of in conformity with the current regulations. In case of scrapping, the automation devices do not entail any particular risks or danger. In case of materials to be recycled, these should be sorted out by type (electrical components, batteries, copper, aluminium, plastic etc.).

22) DISMANTLING

When the automation system is disassembled to be reassembled on another site, proceed as follows:

- Disconnect the power supply and the entire external electrical installation.
- In the case where some of the components cannot be removed or are damaged, they must be replaced.

WARNING! Correct controller operation is only ensured when the data contained in the present manual are observed. The company is not to be held responsible for any damage resulting from failure to observe the standards relating to safety, installation and good technical practice, as well as the instructions contained in the present manual.

The descriptions and illustrations contained in the present manual are not binding. The Company reserves the right to make any alterations deemed appropriate for the technical, manufacturing and commercial improvement of the product, while leaving the essential product features unchanged, at any time and without undertaking to update the present publication.

PROGRAMMING

Close jumper J1 in the control unit

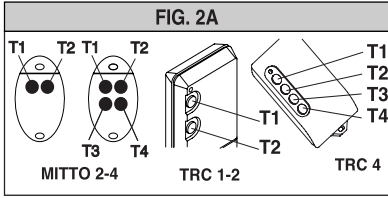
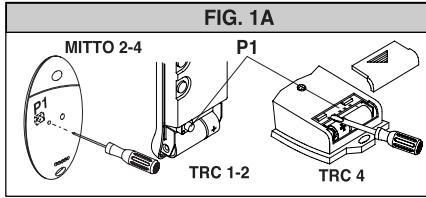



LEGEND

Green		On
		...Blinking
LED		...Emits 1 blink
		Off
Red		On
		...Blinking
LED		...Emits 1 blink
		Off

Menu A

Simultaneously press control unit keys SW1 and SW2 once and release



Green

Red

Menu A - TRANSMITTER STORAGE

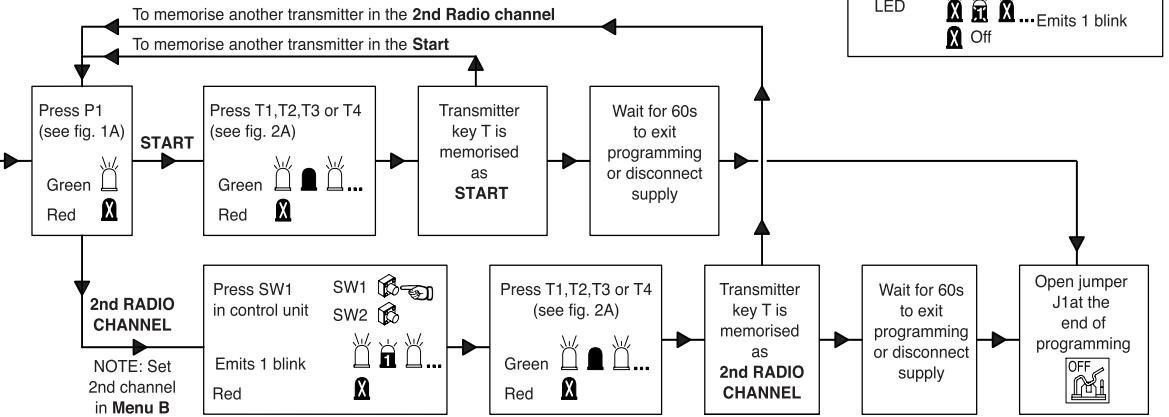

Menu B

Simultaneously press control unit keys SW1 and SW2 once and release

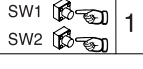

Green

1 blink 1 pause

Menu B - FUNCTION LOGIC SETTINGS

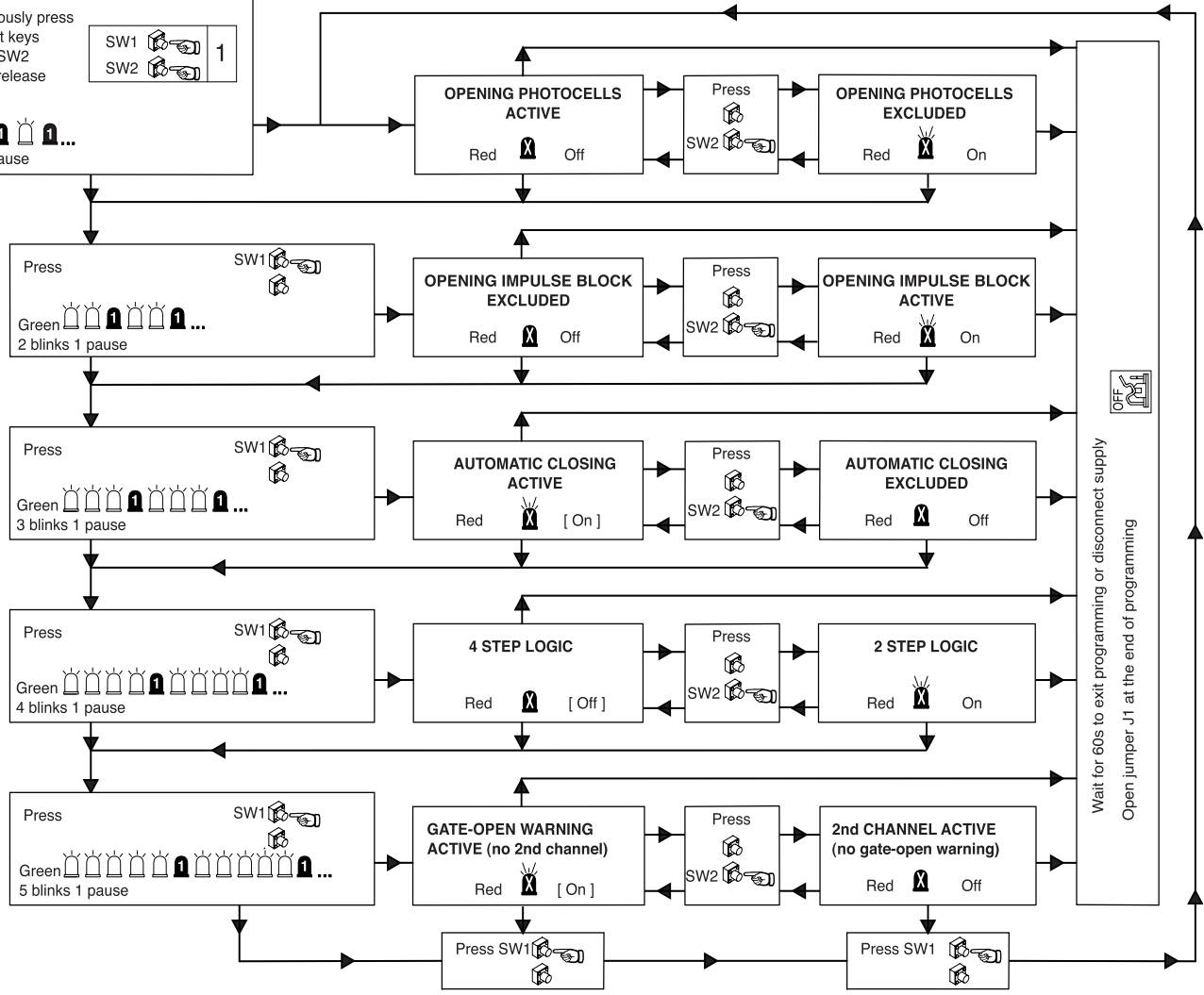

Menu C

PROGRAMMING

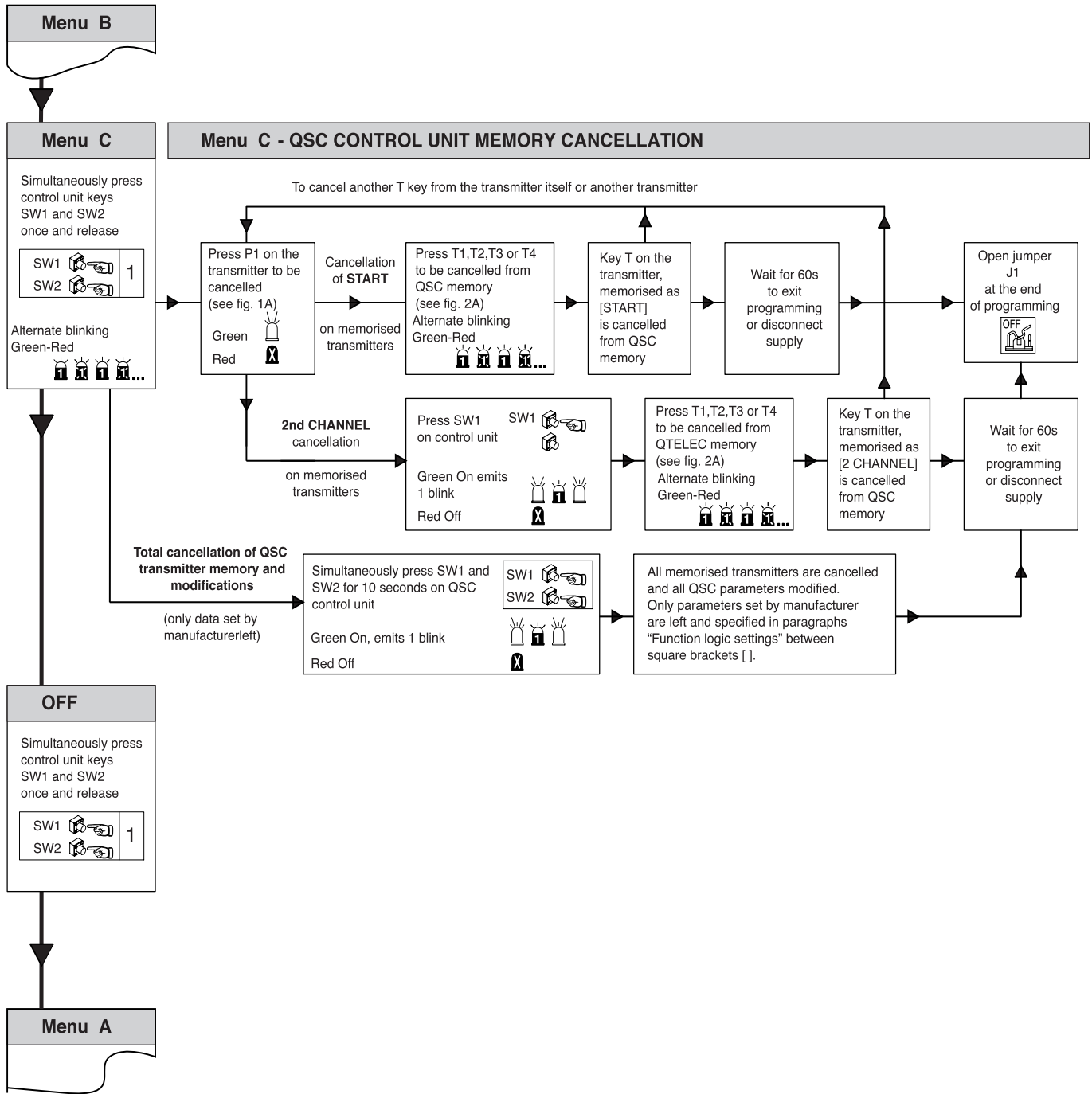

Fig. 1

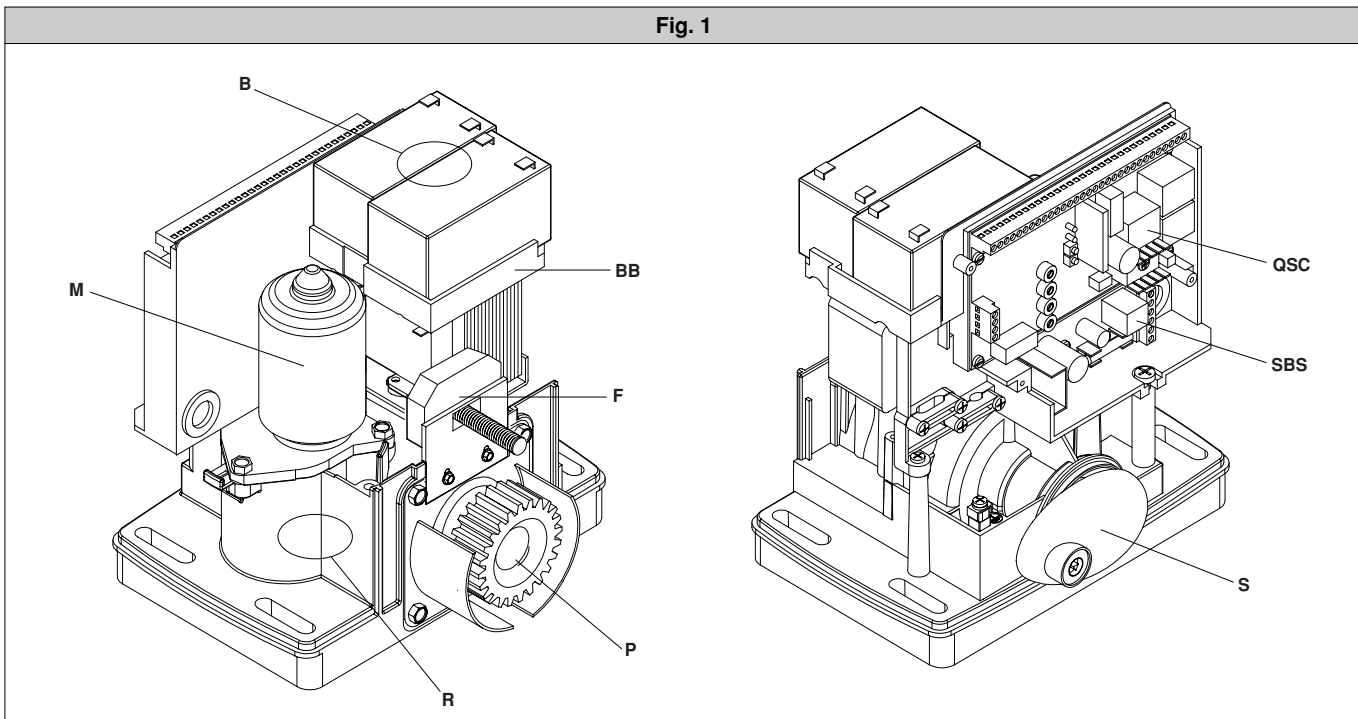

Fig. 2

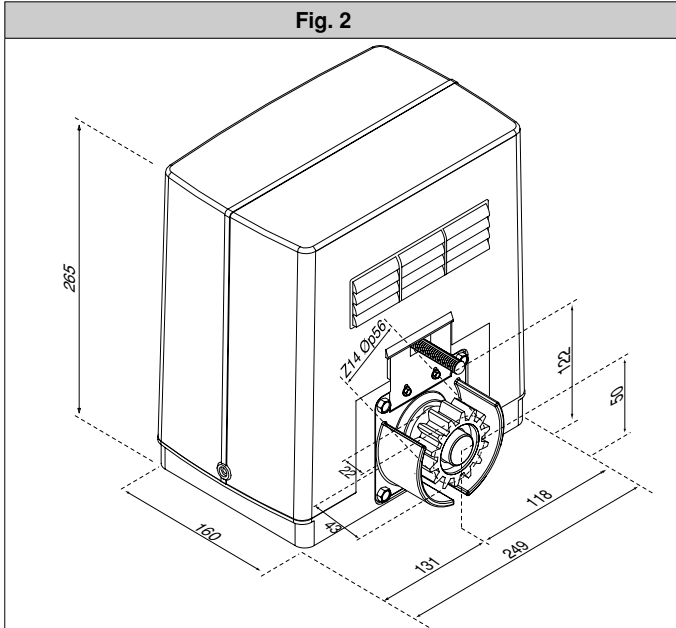

Fig. 3

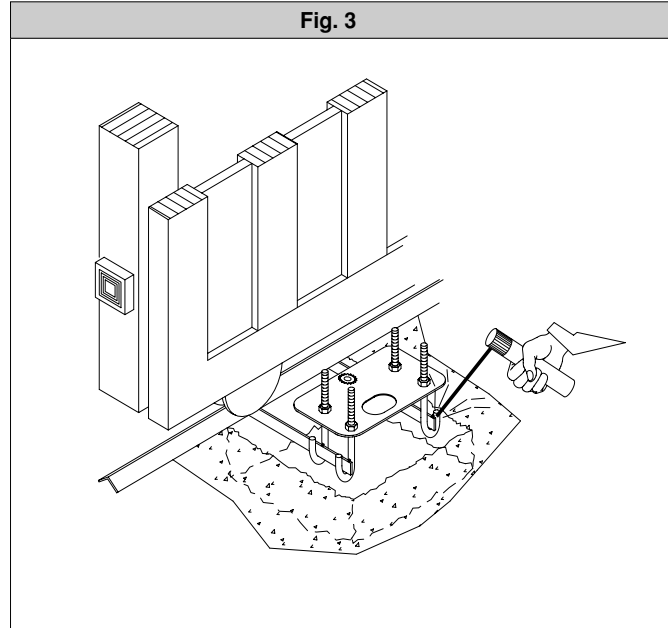

Fig. 4

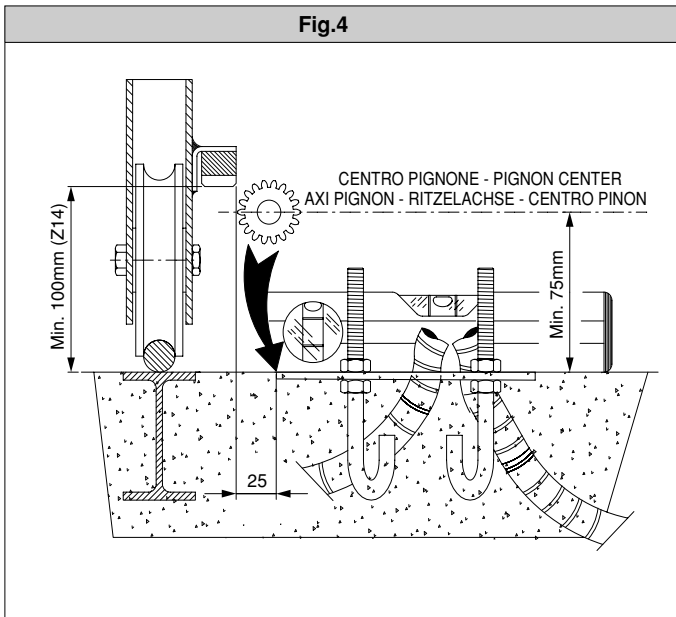

Fig. 5

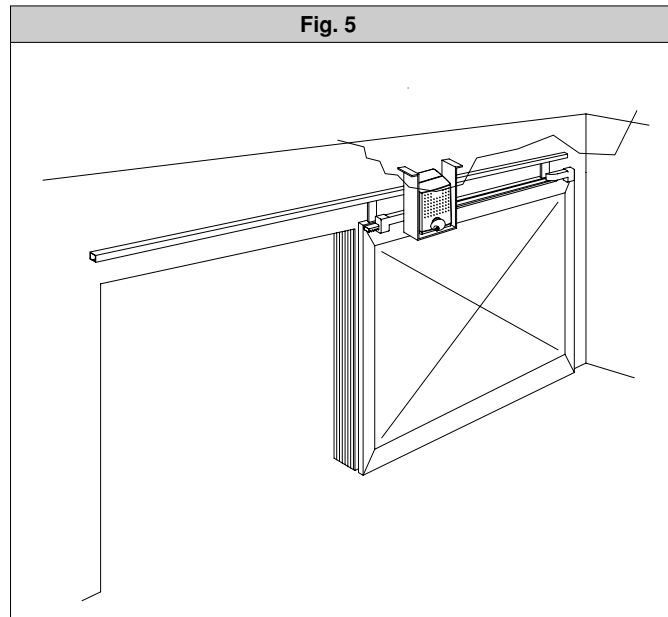

Fig. 6

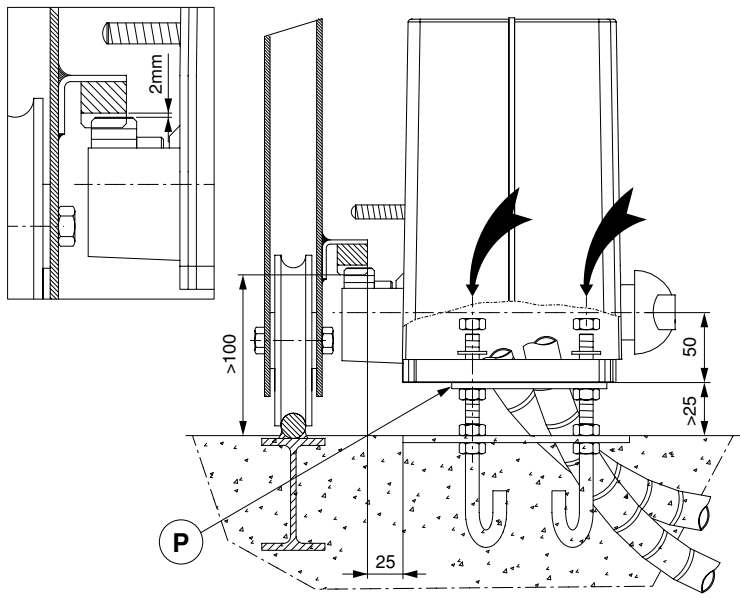

Fig. 7

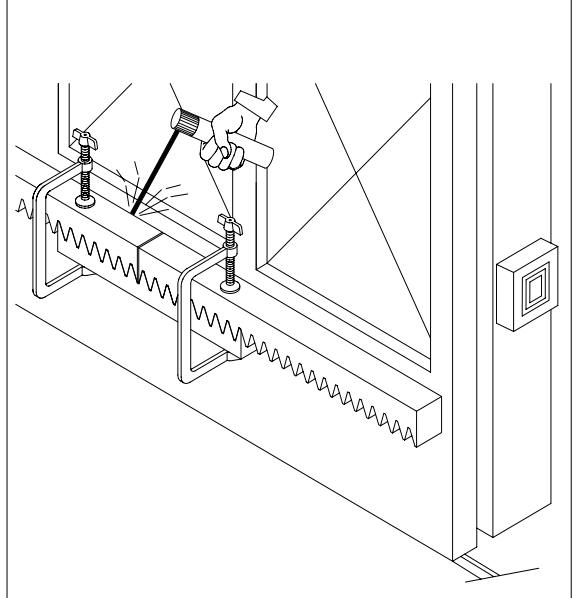

Fig. 8

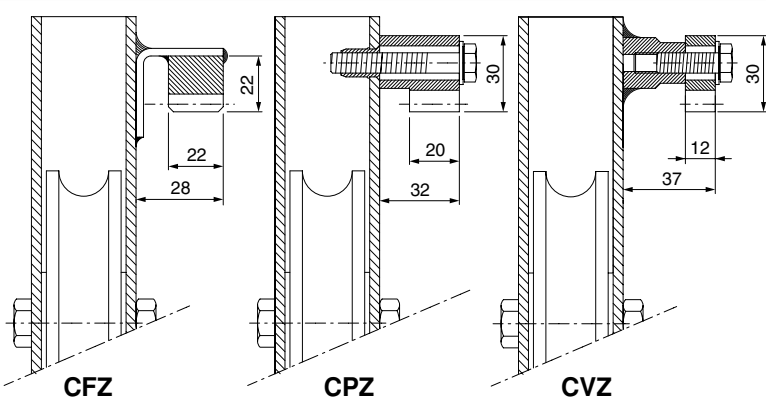

Fig. 9

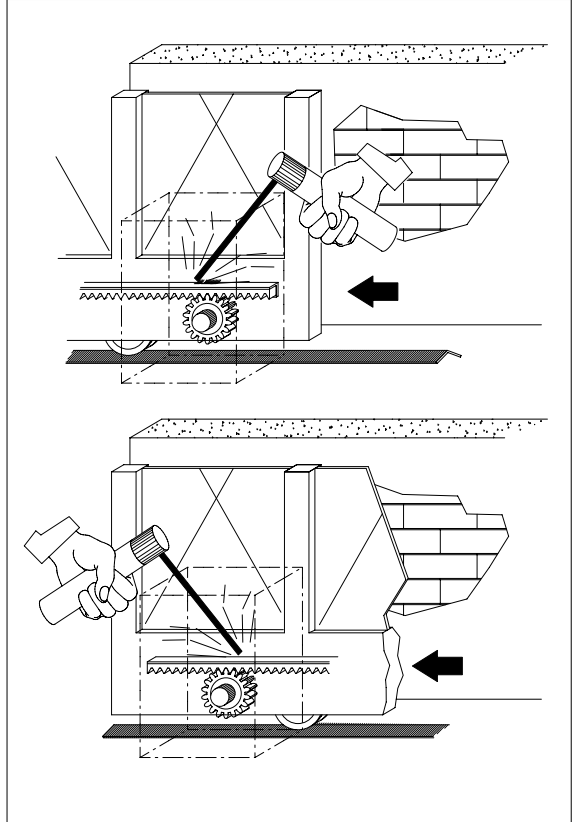

Fig. 10

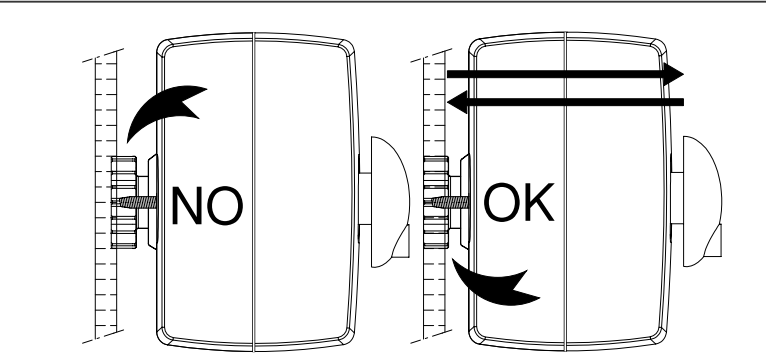

Fig. 11

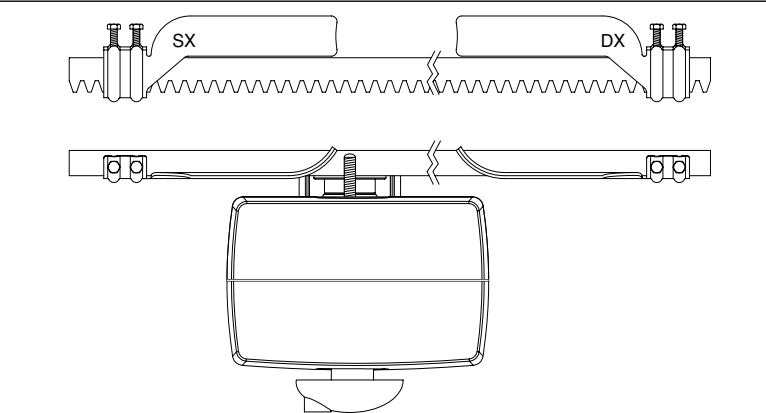

Fig. 12

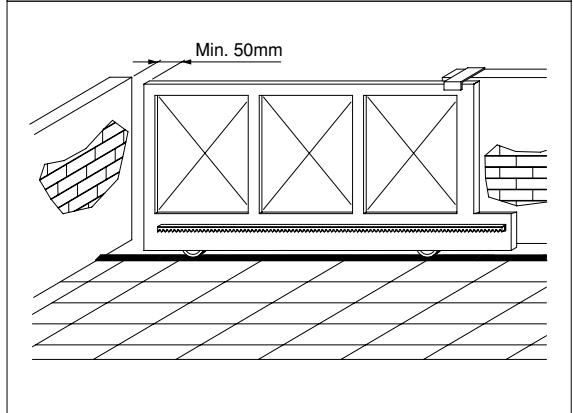

Fig. 13

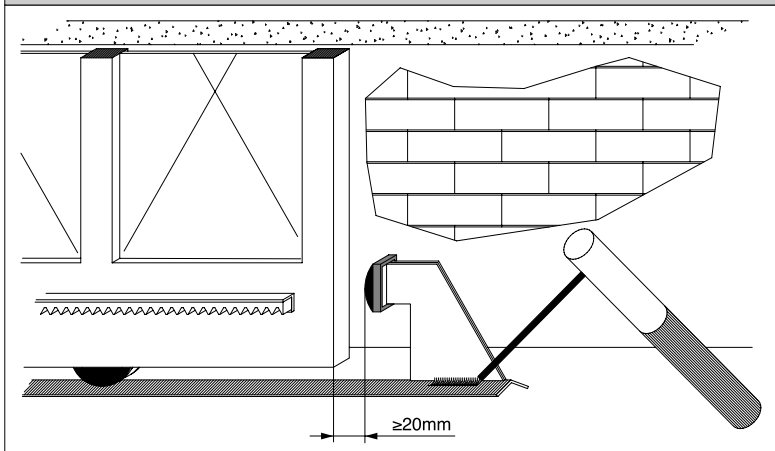

Fig. 14

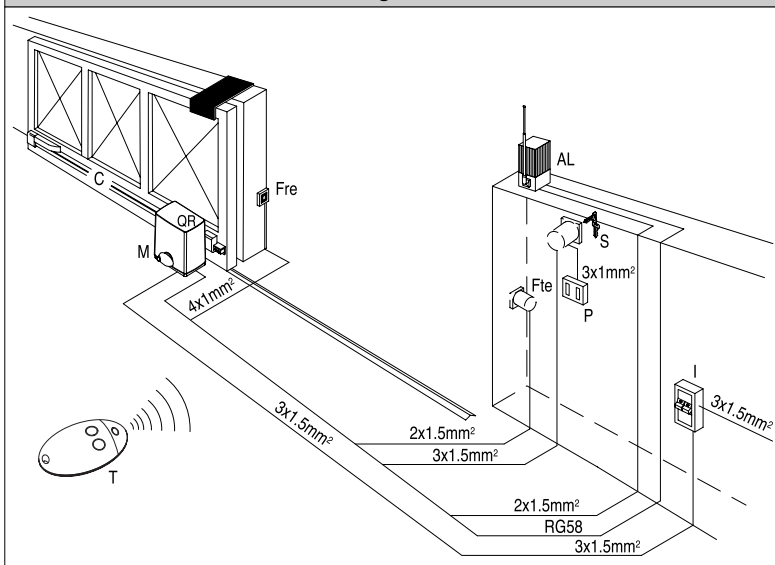

Fig. 15

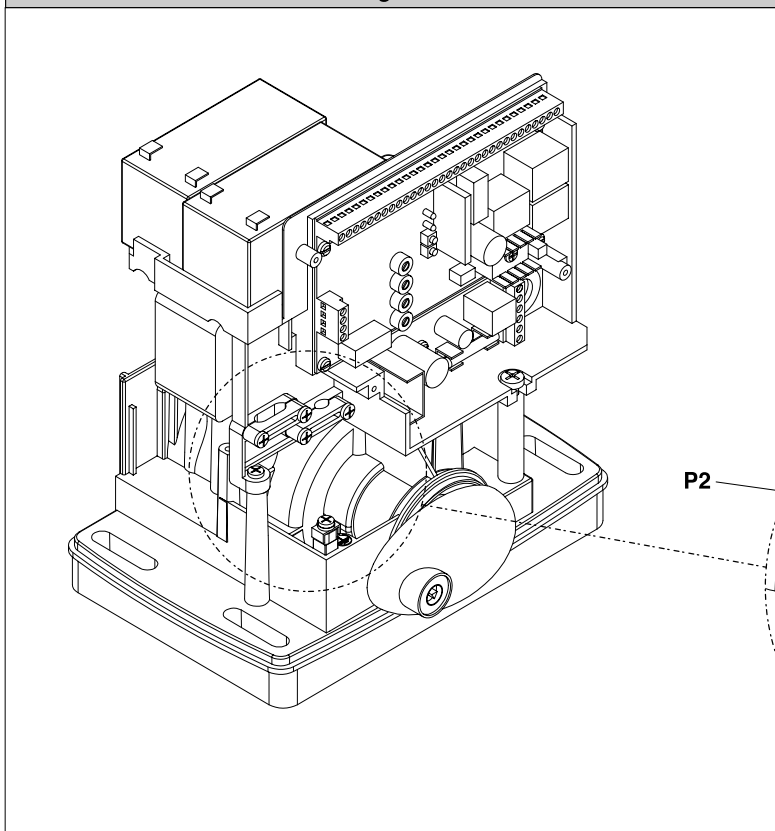

Fig. 16

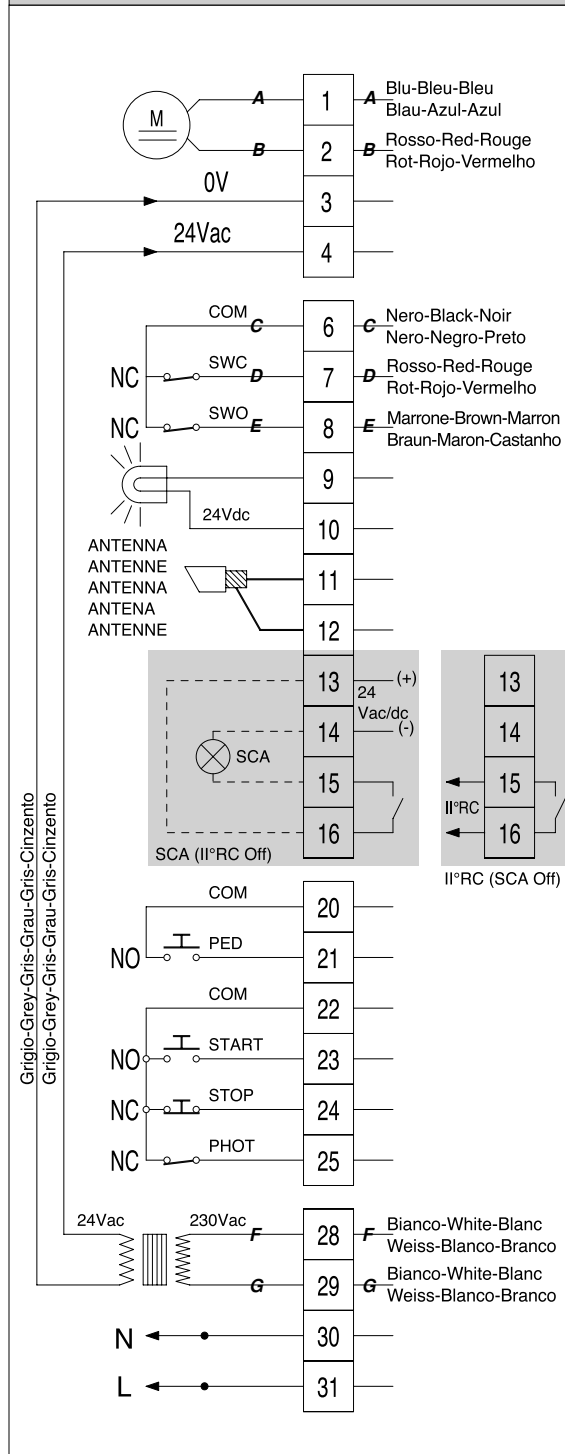

Fig. 17

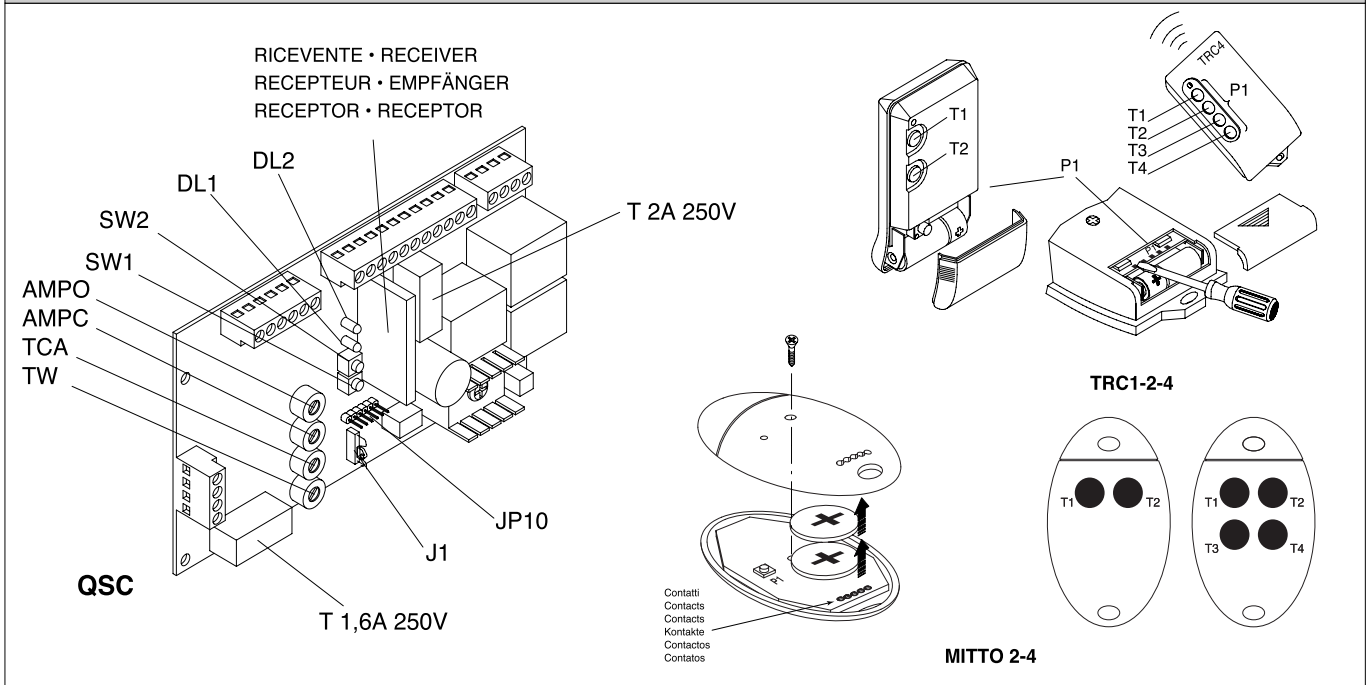

Fig. 18

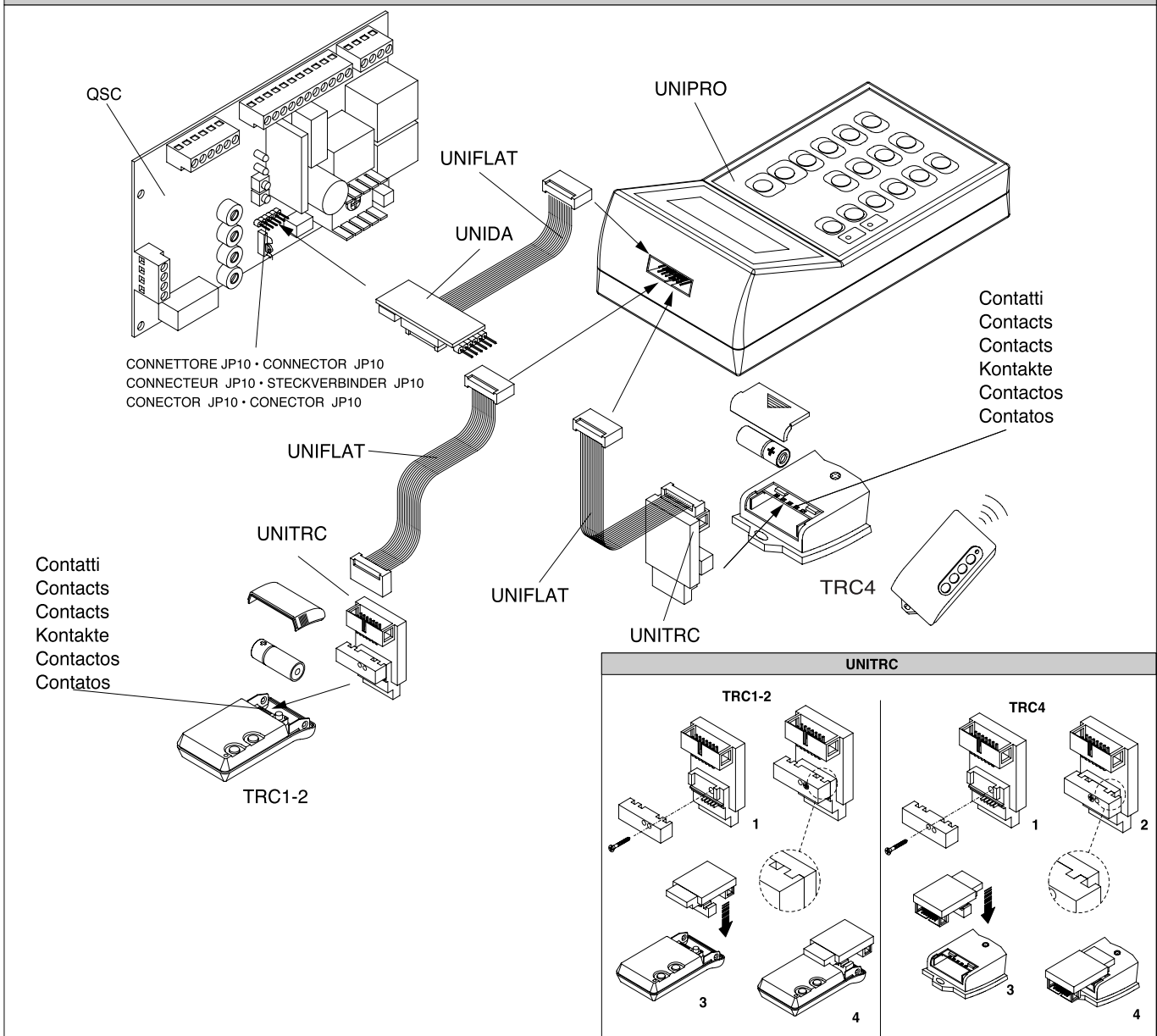
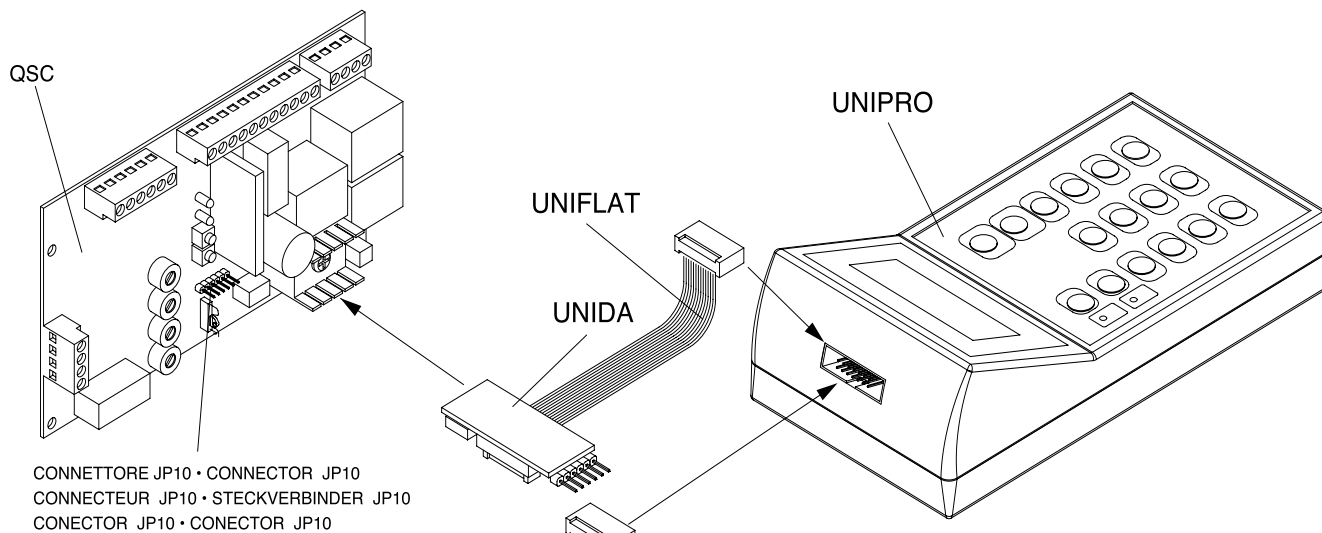

Fig. 19



90

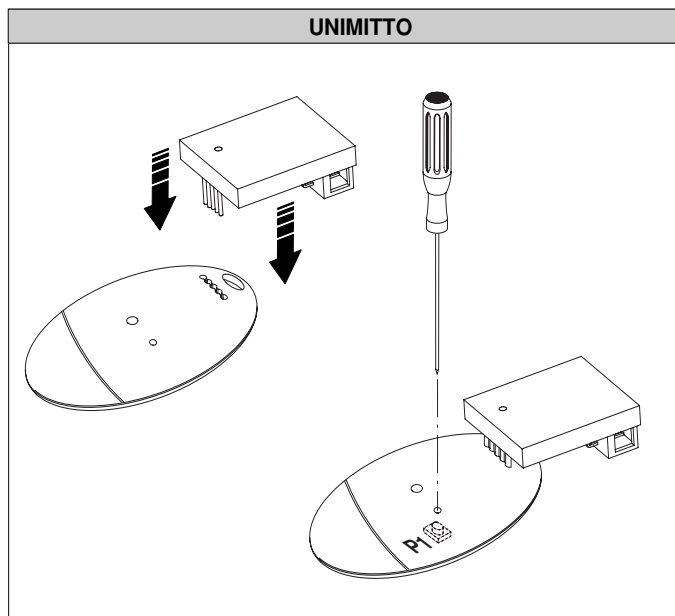
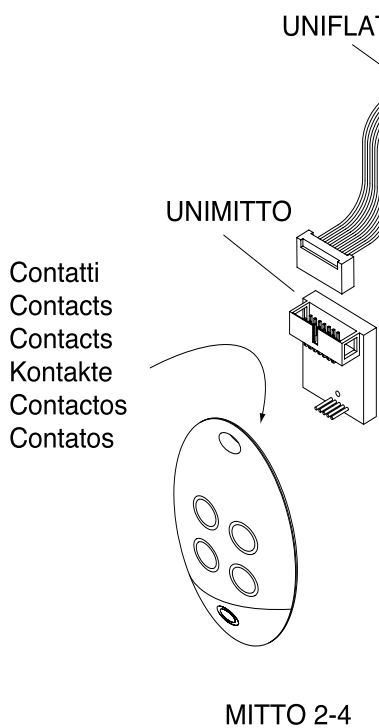

Fig. 20

